



FCS-1

**Einsatzfahrzeug-
Beleuchtung
für Faller* Car-System**

**Emergency vehicle light
compatible to the
Faller* Car-System**

**Feux à éclat
pour véhicules
du Faller* Car-System**

**Reddingsdienstvoertuigen
verlichting voor
het Faller* Car System**

Art.-Nr. 22-01-071



Table of contents

How to use this manual	16
Intended use	17
Safety instructions	17
EMC declaration	19
Summary of operation	20
Technical specifications	21
Circuit Diagram (Fig. 1)	21
Checking the package contents	22
Required tools and materials	22
Safe and correct soldering	22
Mounting the FCS-1	24
Connections (Fig. 2)	25
FAQ	26
Manufacturer's note	27
Certification	27
Conditional warranty	27

How to use this manual

If you have no specialist technical training, this manual gives step-by-step instructions for safe and correct fitting of the module, and operation. Before you start, we advise you to read the whole manual, particularly the chapter on safety instructions and the FAQ chapter. You will then know where to take care and how to prevent mistakes which take a lot of effort to correct.

Keep this manual safely so that you can solve problems in the future. If you pass the module on to another person, please pass on the manual with it.

Intended use



Caution:

Integrated circuits are very sensitive to static electricity. Do not touch components without first discharging yourself. Touching a radiator or other grounded metal part will discharge you.

The module can be used according to the specifications of this manual in a vehicle compatible to the Faller* Car-System. It is designed to drive up to five outputs which can be connected to LEDs.

The module is not suitable for children under the age of 14.

Reading, understanding and following the instructions in this manual are mandatory for the user.

Any other use is inappropriate and invalidates any guarantees.

Safety instructions

Mechanical hazards

Cut wires can have sharp ends and can cause serious injuries. Watch out for sharp edges when you pick up the PCB.

Visibly damaged parts can cause unpredictable danger. Do not use damaged parts: recycle and replace them with new ones.

Electrical hazards

- Touching powered, live components,
- touching conducting components which are live due to malfunction,
- short circuits,
- connecting the circuit to another voltage than specified,
- impermissibly high humidity,
- condensation build up

can cause serious injury due to electrical shock. Take the following precautions to prevent this danger:

- Never perform wiring on a powered module.
- Mounting the module should only be done in closed, clean, dry rooms. Beware of humidity.
- Only use low power for this module as described in this manual and only use certified transformers.
- Connect soldering irons only in approved mains sockets installed by an authorised electrician.
- Observe cable diameter requirements.
- After condensation build up, allow a minimum of 2 hours for dispersion.
- Use only original spare parts if you have to repair the kit or the ready-built module.

Fire risk

Touching flammable material with a hot soldering iron can cause fire, which can result in injury or death through burns or suffocation. Connect your soldering iron or soldering station only when actually needed. Always keep the soldering iron away from inflammable materials. Use a suitable soldering iron stand. Never leave a hot soldering iron or station unattended.

Thermal danger

A hot soldering iron or liquid solder accidentally touching your skin can cause skin burns. As a precaution:

- use a heat-resistant mat during soldering,
- always put the hot soldering iron in the soldering iron stand,
- point the soldering iron tip carefully when soldering, and
- remove liquid solder with a thick wet rag or wet sponge from the soldering tip.

Dangerous environments

A working area that is too small or cramped is unsuitable and can cause accidents, fires and injury. Prevent this by working in a clean, dry room with enough freedom of movement.

Other dangers

Children can cause any of the accidents mentioned above because they are inattentive and not responsible enough. Children under the age of 14 should not be allowed to work with this module.

Little children can swallow small components with sharp edges, with fatal results! Do not allow components to reach small children.

In schools, training centres, clubs and workshops, assembly must be supervised by qualified personnel.

In industrial institutions, health and safety regulations applying to electronic work must be adhered to.

EMC declaration

This product is developed in accordance with the European standards EN 55014 and EN 50082-1, tested corresponding to the EC - directive 89/336/EWG (EMVG of 09/11/1992, electromagnetic tolerance) and meets legal requirements.

To guarantee the electromagnetic tolerance you must take the following precautions:

- Make no changes to the original parts and accurately follow the instructions, circuit diagram and connections diagrams included with this manual.
- Use only original spare parts if you have to repair module.

Summary of Operation

The module is designed for the use in vehicles compatible to the Faller* car system. The voltage of 2,4 V that is provided by the vehicle accumulator batteries, is doubled by the module. This enables white and blue LEDs to be connected, which normally need a voltage of more than 2,4 V.

Flashing lights

The module has five outputs for the direct connection of LEDs, additional series resistors are not necessary when using these outputs. According to the connection of the input, two different programs control the outputs:

Program 1 „Double flashlight“: The LEDs connected to the five outputs flash twice each and then go out for a short time. The LEDs connected to two of the five outputs double flash alternately. The other three outputs generate an asynchronous double flash which is interrupted by different intervals.

Programm 2 „Alternating flashlight“: Two of the five outputs generate an alternating flash, two others, an alternating double flash. The LED connected to the fifth output flashes with a frequency of its own which is not synchronized to the frequency of the other outputs.

Front lighting

It is possible to connect up to two additional white LEDs for the front lighting to the output. In this case they have to be operated via series resistors, otherwise the connected LEDs are damaged and the circuit may not work as intended.

It is not necessary to use all outputs. It is also possible to use the module only for connecting LEDs for the front lighting.

Technical specifications

Supply voltage	2 to 3 Volt D.C.
Current consumption (without connected loads)	approx. 2 mA
Max. total current	40 mA
Max. current per output	10 mA
Protected to	IP 00
Ambient temperature in use	0 - + 60 °C
Ambient temperature in storage	-10 - + 80 °C
Comparative humidity allowed	max. 85 %
Dimensions	approx. 12 x 18 x 2,1 mm
Weight	approx. 0,5 g

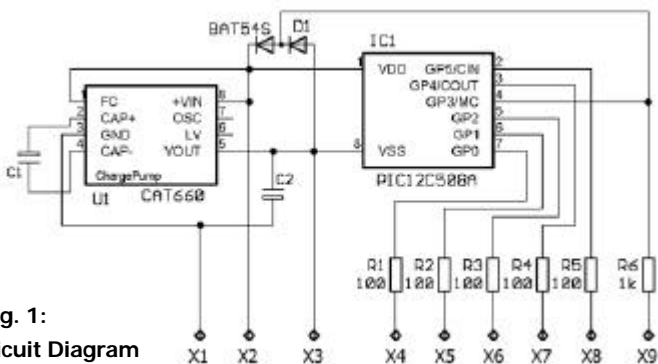

Fig. 1:
Circuit Diagram

Checking the package contents

Check the contents of the package for completeness immediately after unpacking:

- one module,
- one manual.

Required tools and materials

Make sure you have the following tools, equipment and materials ready for use:

- an electronic soldering iron (max. 30 Watt) with a fine tip,
- a soldering iron stand,
- a tip-cleaning sponge,
- a heat-resistant mat,
- a small side cutter and wire stripper,
- a pair of tweezers,
- tin solder (0,5 mm. diameter),
- wire.

Safe and correct soldering



Caution:

Incorrect soldering can cause dangers through fires and heat. Avoid these dangers by reading and following the directions given in the chapter **Safety instructions**. If you have had training in soldering you can skip this chapter.

- Use a small soldering iron with max. 30 Watt. Keep the soldering tip clean so the heat of the soldering iron is applied to the solder point effectively.
- Only use tin solder SN 60 Pb (i.e. 60 % tin, 40 % lead) with rosin-based flux.

- When soldering electronic circuits never use soldering-water or soldering grease. They contain acids that can corrode components and copper tracks.
- Solder quickly: holding the iron on the joints longer than necessary can destroy components and can damage copper tracks or soldering eyes.
- Apply the soldering tip to the soldering spot in such a way that the wire and the soldering eye are heated at the same time. Simultaneously add solder (not too much). As soon as the solder becomes liquid take it away. Hold the soldering tip at the spot for a few seconds so that the solder flows into the joint, then remove the soldering iron.
- The joint should be held still for about 5 seconds after soldering. A glossy and perfect soldering spot should remain..
- To make a good soldering joint you should use a clean and unoxidised soldering tip. Clean the soldering tip with a damp piece of cloth, a damp sponge or a piece of silicon cloth.
- After soldering check (preferably with a magnifying glass) tracks for accidental solder bridges and short circuits. This would cause faulty operation or, in the worst case, permanent damage. You can remove excess solder by putting a clean soldering tip on the spot. The solder will become liquid again and flow from the soldering spot to the soldering tip.

Mounting the FCS-1

Open the housing of the vehicle. Locate the position for the module. Follow the connection diagram fig. 2.

Connection to the supply voltage

Connect the soldering point X1 to the negative pole and the soldering point X2 to the positive pole of the accumulator batteries.

Caution:

The module should not be connected the wrong way round. Otherwise it will be destroyed when put into operation.

Connection of the diodes for the flashlights

Connect the anodes of the LEDs to the soldering points X4 to X8 and the cathodes to the soldering point X3. Note the different functions of the outputs (see list „Connections“ below fig. 2). Additional series resistors are not necessary for the operation of these LEDs.

When you want to run program 2 („Alternating flashlight“) you have to make a connection between the soldering points X9 and X3. Otherwise the program 1 („Double flashlight“) is performed.

Connection of the diodes for the front light

You may connect up to two white LEDs for the front lighting to the module. Connect the anodes of the LEDs to the soldering point X2 and the cathodes to the soldering point X3.

Caution:

The LEDs for the front lighting must be operated via series resistors. Otherwise the connected LEDs are damaged and the circuit may not work as intended.

You find tips for the computation of the series resistors on page 26.

Fig. 2: Connections

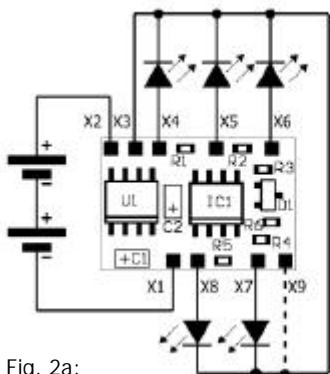
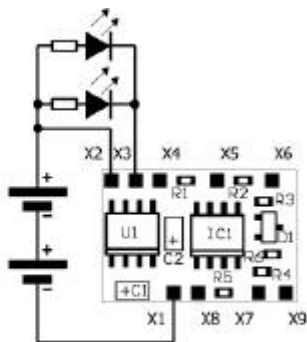
Fig. 2a:
Connection flash lightsFig. 2b:
Connection front lights

Connections

X1	Connection to „-“ of the accumulator batteries
X2	Connection to „+“ of the accumulator batteries / front lighting
X3	Voltage output (-) of the circuit

Program 1 „Double flashlight“	
X4	double flashlight
X5	double flashlight
X6	alternating
X7	double flashlight
X8	double flashlight
X9	input of the circuit --> open

Program 2 „Alternating flashlight“	
X4	alternating
X5	double flashlight
X6	alternating
X7	flashlight
X8	flashlight
X9	input of the circuit --> connected to X3

Computation of the series resistors for the front light LEDs

In order to spare the accumulator batteries it is recommended to restrict the input of the LEDs for the front lighting to approx. 10 mA. This guarantees as well a sufficient brightness. In this case you can determine the series resistor from the following formula:

$$R = (U_B - U_F) / I = (4,8 - U_F) / 0,01$$

R: necessary series resistor [Ohm]

U_B : voltage at the voltage output of the circuit [V]

U_F : forward voltage of the LED [V]

I: Current through the LED [A]

Example for a LED with $U_F = 4$ V:

$$R = (4,8 - 4,0) / 0,01 = 80 \text{ Ohm}$$

As the calculated value in this example does not correspond to a commercial resistor we choose the next lower value, that means a resistor of 68 Ohm. The input of the LED then is ca. 12. mA.

FAQ

- Parts are getting very hot and/or start to smoke.



Disconnect the system from the mains immediately!

Possible cause: The connections to the power supply are connected the wrong round.

→ Check the connection. In this case the module is probably damaged irreparably.

- The LEDs do not light / flash.

Possible cause: The LEDs are connected the wrong round. → Check the connections.

Possible cause: The power supply is interrupted. → Check the connections.

If you cannot find the problem, please return the module for repair (address on the cover page).

Manufacturer's note

According to DIN VDE 0869, the person who assembles and/or mounts a circuit in its' casing is the manufacturer of the product. If he sells the product to another person he is responsible for passing on all the relevant papers and his name and address.

Certification

This product conforms with the EC- directive 89/336/EWG on electromagnetic radiation and is therefore CE certified.

Conditions of warranty

This product is guaranteed for two years. The warranty includes the correction of faults which can be proved to be due to material failure or factory flaw. We guarantee the function of the parts according to the parameters in not mounted state as well as the adherence to the technical specifications of the circuit when assembled and connected according to the manual.

Other claims are excluded. By law, we are not responsible for damages or secondary damages in connection with this product. We retain the right to repair, make improvements, supply spare parts or return the purchase price.

The following invalidate the warranty:

- using an unsuitable soldering iron, solder containing liquid acids or similar,
- if damage is caused by not following the instructions in this manual or the connection diagram(s)
- if the module has been altered and repair attempts have failed,
- if arbitrary changes in the circuit are made,
- if additional components are added which are not described in the manual,

- if the copper tracks or soldering eyes are damaged,
- if damage occurs due to an overload of the module,
- if connected to a incorrect voltage or current,
- if damaged by other persons,
- if damaged by faulty operation or if damaged by careless use or abuse,
- if damaged by touching components before electrostatic discharging of the hands.

* **"Faller"** is a registered and protected trade mark of Gebrueder Faller GmbH, Guetenbach, Germany.

Aktuelle Informationen und Tipps:

Information and tips:

Informations et conseils:

Actuele informatie en tips:

<http://www.tams-online.de>

Garantie und Service:

Warranty and service:

Garantie et service:

Garantie en service:

Tams Elektronik GmbH

Rupsteinstraße 10

D-30625 Hannover

fon: +49 (0)511 / 55 60 60

fax: +49 (0)511 / 55 61 61

e-mail: modellbahn@tams-online.de