



## **FCS-2**

**Fahrzeugmodul  
für Faller\* Car-System**

**Vehicle module compatible  
to the Faller\* Car-System**

**Module pour véhicule  
du Faller\* Car-System**

**Voertuigmodule voor  
het Faller\* Car System**

Art.-Nr. 22-01-071-2





## Table of contents

How to use this manual	17
Intended use	18
Safety instructions	18
EMC declaration	20
Summary of operation	21
Technical specifications / Circuit Diagram(Fig. 1)	22
Checking the package contents	23
Required tools and materials	23
Safe and correct soldering	23
Special features of the additional components	24
Mounting the FCS-2	26
FAQ	29
Manufacturer's note	29
Certification	29
Conditional warranty	30
Connections (Fig. 2)	II
(Page II in the centre of this handbook is removeable.)	

## How to use this manual

If you have no specialist technical training, this manual gives step-by-step instructions for safe and correct fitting of the module, and operation. Before you start, we advise you to read the whole manual, particularly the chapter on safety instructions and the FAQ chapter. You will then know where to take care and how to prevent mistakes which take a lot of effort to correct.

Keep this manual safely so that you can solve problems in the future. If you pass the module on to another person, please pass on the manual with it.

## Intended use



### Caution:

Integrated circuits are very sensitive to static electricity. Do not touch components without first discharging yourself. Touching a radiator or other grounded metal part will discharge you.

The module can be used according to the specifications of this manual in a vehicle compatible to the Faller\* Car-System.

The module is not suitable for children under the age of 14.

Reading, understanding and following the instructions in this manual are mandatory for the user.

Any other use is inappropriate and invalidates any guarantees.

## Safety instructions

### Mechanical hazards

Cut wires can have sharp ends and can cause serious injuries. Watch out for sharp edges when you pick up the PCB.

Visibly damaged parts can cause unpredictable danger. Do not use damaged parts: recycle and replace them with new ones.

### Electrical hazards

- Touching powered, live components,
- touching conducting components which are live due to malfunction,
- short circuits,
- connecting the circuit to another voltage than specified,
- impermissibly high humidity,
- condensation build up

can cause serious injury due to electrical shock. Take the following precautions to prevent this danger:

- Never perform wiring on a powered module.
- Mounting the module should only be done in closed, clean, dry rooms. Beware of humidity.

- Only use low power for this module as described in this manual and only use certified transformers.
- Connect soldering irons only in approved mains sockets installed by an authorised electrician.
- Observe cable diameter requirements.
- After condensation build up, allow a minimum of 2 hours for dispersion.
- Use only original spare parts if you have to repair the kit or the ready-built module.

### **Fire risk**

Touching flammable material with a hot soldering iron can cause fire, which can result in injury or death through burns or suffocation. Connect your soldering iron or soldering station only when actually needed. Always keep the soldering iron away from inflammable materials. Use a suitable soldering iron stand. Never leave a hot soldering iron or station unattended.

### **Thermal danger**

A hot soldering iron or liquid solder accidentally touching your skin can cause skin burns. As a precaution:

- use a heat-resistant mat during soldering,
- always put the hot soldering iron in the soldering iron stand,
- point the soldering iron tip carefully when soldering, and
- remove liquid solder with a thick wet rag or wet sponge from the soldering tip.

### **Dangerous environments**

A working area that is too small or cramped is unsuitable and can cause accidents, fires and injury. Prevent this by working in a clean, dry room with enough freedom of movement.

## Other dangers

Children can cause any of the accidents mentioned above because they are inattentive and not responsible enough. Children under the age of 14 should not be allowed to work with this module.

Little children can swallow small components with sharp edges, with fatal results! Do not allow components to reach small children.

In schools, training centres, clubs and workshops, assembly must be supervised by qualified personnel. In industrial institutions, health and safety regulations applying to electronic work must be adhered to.

## EMC declaration

This product is developed in accordance with the European standards EN 55014 and EN 50082-1, tested corresponding to the EC - directive 89/336/EWG (EMVG of 09/11/1992, electromagnetic tolerance) and meets legal requirements.

To guarantee the electromagnetic tolerance you must take the following precautions:

- Make no changes to the original parts and accurately follow the instructions, circuit diagram and connections diagrams included with this manual.
- Use only original spare parts if you have to repair module.

## Summary of operation

The module is particularly designed for the use in vehicles compatible to the Faller\* car system, that are run with two accumulator batteries. It has six in- and outputs for the connection of LEDs, motor, reed contacts and a Dim switch. It is not necessary to use all outputs. The in- and outputs are controlled from the software stored in the IC.

The voltage of 2,4 V that is provided by the vehicle accumulator batteries, is doubled by the module. This enables white LEDs to be connected, which normally need a voltage of more than 2,4 V. Red and yellow LEDs may be connected directly via series resistors to the accumulator batteries, provided they are not to be controlled by the software.

### Front and back lighting

It is possible to connect two white or yellow LEDs to one output of the module for the front lighting, and two red LEDs to another output for the back and stop lights.

Depending on the ambient lighting, the lighting of the vehicle is switched on and off via a light sensitive switch. The sensitivity of the light is set via a trimpot.

While breaking and some seconds after stopping, the back lights are switched brighter, provided that the reed contact existing in the vehicle is connected to the module.

If the vehicle does not receive the signal to drive on for a longer time, all lights connected to the module are switched off (current saving mode).

### Driving of the motor

The reed contact existing in the vehicle can be connected to the module. The module then influences the motor: After a stop it starts gently and while breaking and some seconds after stopping, the back lights are switched brighter. If an additional reed contact is mounted, the vehicle also brakes gently.

## Technical specifications

Supply voltage	2 to 3 Volt D.C.
Current consumption (without connected loads)	approx. 4 mA
Max. total current	80 mA
Max. current per output	20 mA
Protected to	IP 00
Ambient temperature in use	0 - + 60 °C
Ambient temperature in storage	-10 - + 80 °C
Comparative humidity allowed	max. 85 %
Dimensions	approx. 12 x 18 x 2,1 mm
Weight	approx. 0,5 g

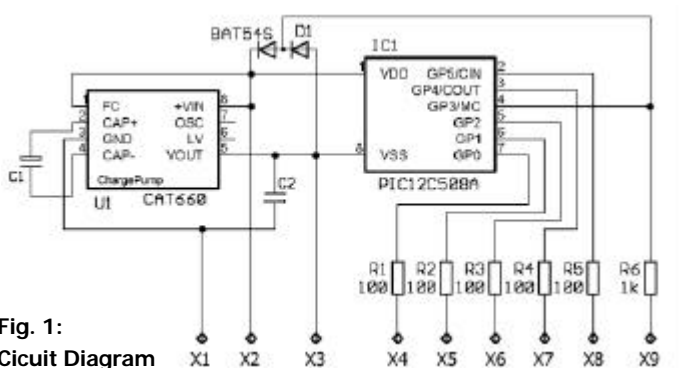

## Checking the package contents

Check the contents of the package for completeness after unpacking:

- one module,
- additional components: two resistors 10  $\Omega$ , one resistor 10 k $\Omega$ , one light sensitive resistor, one diode 1N4148, one transistor BC 327, one reed contact, one Dim switch DS-1,
- one manual.

## Required tools and materials

Make sure you have the following tools and materials ready for use:

- an electronic soldering iron (max. 30 Watt) with a fine tip,
- a soldering iron stand,
- a tip-cleaning sponge and a heat-resistant mat,
- a small side cutter and wire stripper,
- a pair of tweezers,
- tin solder (0,5 mm. diameter),
- enamelled copper wire or thin connecting wire,
- LEDs for the lights.

## Safe and correct soldering



### Caution:

Incorrect soldering can cause dangers through fires and heat. Avoid these dangers by reading and following the directions given in the chapter **Safety instructions**. If you have had training in soldering you can skip this chapter.

- Use a small soldering iron with max. 30 Watt. Keep the soldering tip clean so the heat of the soldering iron is applied to the solder point effectively.
- Only use electronic tin solder with flux.

- When soldering electronic circuits never use soldering-water or soldering grease. They contain acids that can corrode components and copper tracks.
- Solder quickly: holding the iron on the joints longer than necessary can destroy components and can damage copper tracks or soldering eyes.
- Apply the soldering tip to the soldering spot in such a way that the wire and the soldering eye are heated at the same time. Simultaneously add solder (not too much). As soon as the solder becomes liquid take it away. Hold the soldering tip at the spot for a few seconds so that the solder flows into the joint, then remove the soldering iron.
- The joint should be held still for about 5 seconds after soldering.
- To make a good soldering joint you should use a clean and unoxidised soldering tip. Clean the soldering tip with a damp piece of cloth, a damp sponge or a piece of silicon cloth.
- After soldering check (preferably with a magnifying glass) tracks for accidental solder bridges and short circuits. This would cause faulty operation or, in the worst case, permanent damage. You can remove excess solder by putting a clean soldering tip on the spot. The solder will become liquid again and flow from the soldering spot to the soldering tip.

## Special features of the additional components

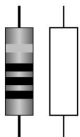

### Resistors

Resistors reduce current. Their mounting orientation is of no importance. The value of resistors for smaller power ratings (under 5 W) is indicated through colour rings. Every colour stands for another figure. The colour ring in brackets indicates the tolerance of the resistor which here is of no importance.

Value	Colour rings
10 $\Omega$	brown - black - black (gold)
10 k $\Omega$	brown - black - orange (gold)

## Light sensitive resistors

Light sensitive resistors change their value depending on the ambient lighting. As a rule types are used which value decrease with increasing light intensity. Their mounting orientation is of no importance.



## Diodes

Diodes allow the current to pass through in one direction only (forward direction). The diode type is printed on the body.

Diodes must be mounted in a given direction. The negative end is marked with a ring.



## Transistors

Transistors are current amplifiers which convert low signals into stronger ones. They have three contacts. As they are polarized, they have to be mounted in a certain direction. Die BC-Types have a housing in form of a half cylinder (SOT-housing). The three connecting points are called basis (B), collector (C) and emitter (E).

## Light emitting diodes (LEDs)

When operated in the forward direction the LEDs light. They are available in several different versions (differing in colour, size, form, luminosity, maximum current, voltage limits). The longer lead of wired LEDs is always the anode (positive pole).

With SMD-LEDs the cathode normally is shown by a mark on the housing.

Light emitting diodes should always be connected via a series resistor which limits the current and prevents failure. With circuits designed for the connection of LEDs the series resistors are often integrated on the circuit board.

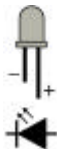

## Trimm-potentiometers

Trimm-potentiometers (abr. „trimm-pots“) are resistors which allow the value of resistance to be varied and that way to be adapted to the particular demands. In the middle they have a small slot into which a small screwdriver can be put in order to vary the value of resistance. The maximum value is printed on the housing.



## Reed contacts

Depending on their version reed contacts fulfill the task of a closer or a change-over switch. They respond to a magnetic field, thus making possible contactless switching operations. They consist of a glass bulb filled with a protective gas. Sealed in the glass bulb are two or three reeds made of a magnetic material. When bending the legs the glass bulb they can be easily damaged through mechanical strain.

# Mounting the FCS-2

## Preparation

Open the housing of the vehicle. Locate the position for the module. Disconnect all connections from the accumulator batteries, the motor and the mounted reed contact except for the wire to the charging contact.

Follow the connection diagram fig. 2 (page II in the centre of this handbook) and the special features of the additional components.

In many vehicles the resistor R7 shown in the connection diagram is mounted into the lead-in wire to the motor. The resistor has to be connected to the plus pole of the accumulator batteries if not yet mounted that way. If there is no resistor, R7 is not applicable.

## Connection to the supply voltage

Connect the connecting point X2 to the plus pole of the accumulator batteries and the minus pole of the accumulator batteries to the existing switch S of the vehicle. Connect the second pole of the switch to the connecting point X1.

**Caution:**

The module should not be connected the wrong way round. Otherwise it will be destroyed when put into operation.

**Connection of the existing reed contact**

The existing reed contact has three connecting points, one at side A and two at side B. Connect the connecting point at side A to the connecting point X1 and the existing switch S.

In order to check which one of the two connecting points of side B you have to connect to the module, connect temporarily the plus pole of the motor to the plus pole of the accumulator batteries and the minus pole of the motor to one of the two connecting points at side B of the reed contact. If the motor does **not** run with this connection, you have to connect this connecting point to the plus pole of the motor and the other connecting point of the reed contact, together with the enclosed resistor R10 (10 kOhm) to X8. If the motor runs with this connection, you have to make the connections the other way round. Connect the second side of the resistor R10 to the connecting point X3.

**Connection of an additional reed contact**

If the vehicle is intended to stop abruptly, the connecting point X9 is not connected and you can skip this section. In order to brake the vehicle gently, an additional reed contact has to be connected, which should be mounted as far as possible in the front of the vehicle. Connect the enclosed reed contact to the connecting points X3 and X9.

**Caution:**

Reed contacts are sensitive to stress. Therefore be careful when bending the legs in order not to destroy the glass bulb.

### **Connection of the motor**

Connect the enclosed diode 1N4148 to the connections of the motor. Observe the polarity of the diode. Then connect the minus pole of the motor to the minus pole of the accumulator batteries. Next connect the collector (C) of the enclosed transistor BC 327 to the plus pole of the motor, the basis (B) to the connecting point X7 and the emitter (E) to the resistor R7. If there is no resistor R7, connect the emitter directly to the plus pole of the accumulator batteries.

### **Connection of the Dim switch**

Connect the connecting points X2, X3 and X5 of the dimming switch to the connecting points X5, X3 and X2 of the module.

Next connect the enclosed light depending resistor to the connecting points X3 and X4 of the Dim switch. The light sensitive resistor has to be placed that way it is exposed to the ambient lighting when the housing of the vehicle is closed.

### **Connection of the LEDs for the front and back lights**

The two LEDs for the front lights have to be connected in parallel, i.e. the anodes (+) of the LEDs both have to be connected to X4. Connect the two cathodes (-) to the resistors R8 and R9. Connect the disconnected ends of the resistors to the connecting point X3.

The two LEDs for the stop and back lights have to be connected in series, i.e. the anode (+) of the one LED has to be connected to the cathode (-) of the other LED. Connect the disconnected anode to connecting point X6 and the disconnected cathode to connecting point X3.

### **Setting the sensitivity of the light**

Before closing the housing of the vehicle, you should set the sensitivity of the dim switch to the desired lighting conditions. First set the trim pot to mid-position and change the sensitivity as far as necessary. The circuit requires 3 or 4 seconds to react.

## FAQ

- Parts are getting very hot and/or start to smoke.



### **Disconnect the system from the mains immediately!**

Possible cause: The connections to the power supply are connected the wrong round. → Check the connection. In this case the module is probably damaged irreparably.

- The LEDs do not light.

Possible cause: The LEDs are connected the wrong round. → Check the connections.

Possible cause: The power supply is interrupted. → Check the connections.

- The vehicle does not drive.

Possible cause: The wrong connecting point at side B of the existing reed contact was used. → Check the connection.

- The vehicle drives backwards.

Possible cause: The connections of the motor are connected reverse. → Check the connections.

If you cannot find the problem, please return the module for repair (address on the cover page).

## Manufacturer's note

According to DIN VDE 0869, the person who assembles and/or mounts a circuit in its' casing is the manufacturer of the product. If he sells the product to another person he is responsible for passing on all the relevant papers and his name and address.

## Certification

This product conforms with the EC- directive 89/336/EWG on electromagnetic radiation and is therefore CE certified.

## Conditions of warranty

This product is guaranteed for two years. The warranty includes the correction of faults which can be proved to be due to material failure or factory flaw. We guarantee the function of the parts according to the parameters in not mounted state as well as the adherence to the technical specifications of the circuit when assembled and connected according to the manual.

Other claims are excluded. By law, we are not responsible for damages or secondary damages in connection with this product. We retain the right to repair, make improvements, supply spare parts or return the purchase price.

The following invalidate the warranty:

- using an unsuitable soldering iron, solder containing liquid acids or similar,
- if damage is caused by not following the instructions in this manual or the connection diagram(s)
- if the module has been altered and repair attempts have failed,
- if arbitrary changes in the circuit are made,
- if additional components are added which are not described in the manual,
- if the copper tracks or soldering eyes are damaged,
- if damage occurs due to an overload of the module,
- if connected to a incorrect voltage or current,
- if damaged by other persons,
- if damaged by faulty operation or if damaged by careless use or abuse,
- if damaged by touching components before electrostatic discharging of the hands.

\* "**Faller**" is a registered and protected trade mark of Gebrueder Faller GmbH, Guetenbach, Germany.

Fig. 2: Connections

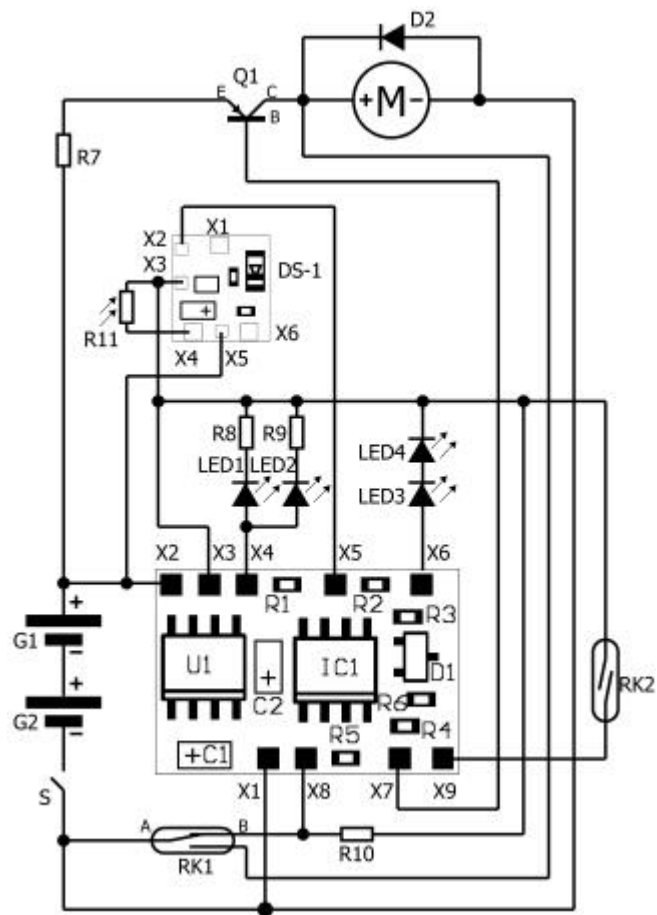

### Connection Table

X1	Connection to „-“ of the accumulator batteries
X2	Connection to „+“ of the accumulator batteries
X3	Voltage output (-) of the circuit
X4	Front lighting
X5	Light sensitive switch
X6	Braking and reversing lights
X7	Motor control
X8	Existing reed contact
X9	Secondary reed contact

### External Components

D2	Additional diode (1N4148)
G1, G2	Existing accumulator batteries
LED1*, LED2*	White LEDs for front lighting
LED3*, LED4*	Red LEDs for braking and reversing lights
DS-1	Dim switch
M	Motor
Q1	Additional Transistor (BC 327)
R7	Existing resistor
R8, R9	Additional resistors for LED1 / LED2 (10Ω)
R10	Additional resistor (10 kΩ)
R11	Light sensitive resistor
RK1	Existing reed contact
RK2	Additional reed-contact
S	Existing switch

\* Not supplied.

Aktuelle Informationen und Tipps:

Information and tips:

Informations et conseils:

Actuele informatie en tips:

**<http://www.tams-online.de>**

Garantie und Service:

Warranty and service:

Garantie et service:

Garantie en service:

**Tams Elektronik GmbH**

Rupsteinstraße 10

D-30625 Hannover

fon: +49 (0)511 / 55 60 60

fax: +49 (0)511 / 55 61 61

e-mail: [modellbahn@tams-online.de](mailto:modellbahn@tams-online.de)