

FD-4

Funktionsdecoder
Motorola-II-Format

Function decoder
Motorola-II-Format

Décodeur de fonctions
Format-Motorola II

Func tiedecoder
Motorola-II-format

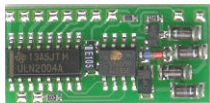

Anleitung

Manual

Mode d'emploi

Handleiding

Art.-Nr. 22-01-038



Table of contents

How to use this manual	18
Intended use	18
Safety instructions	19
EMC declaration	21
INFORMATION: Speed mode	21
INFORMATION: Configuration variables	21
Operation overview	22
Technical specifications	24
Checking the package contents	24
Required tools and consumables	24
Safe and correct soldering	25
Performing a visual check	25
Mounting the function decoder	26
Programming the function decoder	28
FAQ	29
Manufacturer's note	29
Certification	30
Conditional warranty	30
Connections Diagram (Fig. 1)	I
Circuit Diagram (Fig. 2)	II

(Pages I and II in the centre of this handbook are removeable.)

How to use this manual

If you have no specialist technical training, this manual gives step-by-step instructions for safe and correct fitting of the module, and operation. Before you start, we advise you to read the whole manual, particularly the chapter on safety instructions and the FAQ chapter. You will then know where to take care and how to prevent mistakes which take a lot of effort to correct.

Keep this manual safely so that you can solve problems in the future. If you pass the module on to another person, please pass on the manual with it.

Intended use



Caution:

Integrated circuits are very sensitive to static electricity. Do not touch components without first discharging yourself. Touching a radiator or other grounded metal part will discharge you.

The module can be used according to the specifications of this manual. It is designed for a mounting in a model railway locomotive or in a model railway carriage. It evaluates the DCC format data sent by the digital control unit to its address. The decoder has 7 outputs for the connection of optional accessories.

The module is not suitable for children under the age of 14.

Reading, understanding and following the instructions in this manual are mandatory for the user. Any other use of the module is inappropriate and invalidates any guarantees.

Safety instructions

Mechanical hazards

Cut wires can have sharp ends and can cause serious injuries. Watch out for sharp edges when you pick up the PCB.

Visibly damaged parts can cause unpredictable danger. Do not use damaged parts: recycle and replace them with new ones.

Electrical hazards

- Touching powered, live components,
- touching conducting components which are live due to malfunction,
- short circuits,
- connecting the circuit to a higher voltage than designed,
- impermissibly high humidity,
- condensation of water

can cause serious injury due to electrical shock. Take the following precautions to prevent this danger:

- Never perform wiring on a powered module.
- Only use low power for this module as described in this manual and only use certified transformers.
- Connect transformers and soldering stations only in approved mains sockets installed by an authorised electrician.
- Observe cable diameter requirements.
- After the condensation of water do not start working until after a minimum of 2 hours of acclimatisation.
- Mounting the module should only be done in closed, clean, dry rooms. Beware of humidity.
- Use only original spare parts if you have to repair the module.

Fire risk

Touching flammable material with a hot soldering iron can cause life-threatening fire, burns and toxic smoke. Connect your soldering iron or soldering station only when actually needed. Use the correct soldering iron or station and never leave a hot soldering iron or station unattended.

Thermal danger

A hot soldering iron or liquid solder accidentally touching your skin can cause skin burns. As a precaution:

- use a heat-resistant mat during soldering,
- always put the hot soldering iron in the soldering iron stand,
- point the soldering iron tip carefully when soldering, and
- remove liquid solder with a thick wet rag or wet sponge.

Dangerous environments

A working area that is too small or cramped is unsuitable and can cause accidents, fires and injury. Prevent this by working in a clean, dry room with enough freedom of movement.

Other dangers

Children can cause any of the accidents mentioned above because they are inattentive and not responsible enough. Children under the age of 14 should not be allowed to work with this kit or the ready-built module.

Little children can swallow small components with sharp edges. Life threatening! Do not allow components to reach small children.

In schools, training centres, clubs and workshops, assembly must be supervised by qualified personnel.

In industrial institutions, health and safety regulations applying to electronic work must be adhered to.

EMC declaration

This product is developed in accordance with the European standards EN 55014 and EN 50082-1, tested corresponding to the EC - directive 89/336/EWG (EMVG of 09/11/1992, electromagnetic tolerance) and meets legal requirements.

To guarantee the electromagnetic tolerance you must take the following precautions:

- Connect the transformer only to an approved mains socket installed by an authorised electrician.
- Make no changes to the original parts and accurately follow the instructions, circuit diagram and PCB layout included with this manual.
- Use only original spare parts if you have to repair module.

Information: Speed mode

Digital control units for DCC format can send 14, 28 or 128 speed levels depending on the model and the settings. The number of speed levels sent by the control unit (=speed mode) must be set at the decoder as well.

The speed mode set at the digital control unit for a particular decoder address must correspond to the speed mode saved in the function decoder. Otherwise the performance of the decoder may be incorrect.

Information: Configuration variables (CVs)

You can set the so-called configuration variables of the decoder from the control unit. The programming of the variables allows the adjustment of the decoder to the individual needs of the user.

The configuration variables are saved in the decoder and are also preserved if the decoder is switched off. Changing the configuration variables is possible at any time from the digital control unit.

The configuration variables for the DCC format are standardised. The variables that can be set depend on the decoder type.

Operation overview

The decoder is designed for operation in DCC format and can be adjusted to one of 127 basic-addresses. It evaluates the digital data sent by the control unit to its address and switches the accessories connected to the seven outputs via the functions F0 to F4. The functions F5 to F8 are not available with the FD-5.

The configuration variables of the FD-5

The following configuration variables (CVs) can be set from the digital control unit:

- Basic address (CV 1)
- Consist-Address (CV 19)
- Configuration data (CV 29)
- Utilisation and setting of output X9 and X10 (CV 56):
 1. Lighting according to the direction of travel for forward direction or constant light
 2. F4 to switch or lighting according to the direction of travel for backward direction.

Function F0 (Light)

The lights can be switched from the digital control unit. You can either set the lighting according to the direction of travel or a fixed light for both directions of travel by programming the configuration variable CV 56.

Functions F1 and F3

Each of the functions F1 and F3 allow two accessories connected to the outputs X4 and X5 resp. X7 and X8, with a max. current consumption of 500 mA, to be switched on or off. Parallel switching of the outputs is also possible. In this way accessories with a maximum current consumption of up to 900 mA can be switched. They are available for optional accessories (e.g. smoke generator, cab lighting, sound module).

Function F2

The function F2 allows an accessory connected to the output X6, with a maximum current consumption of 500 mA, to be switched on or off.

Function F4

If the configuration variable CV 56 is programmed accordingly, the function F4 allows an optional accessory, connected to the output X9, to be switched on or off. If lighting for reverse direction is programmed for the output X9, the function F4 has no effect on this output.

Point connections

X1	Return conductor for all functions.
X2 und X3	Connections to the rails .
X4 und X5	Two optional accessories with a maximum current consumption of 500 mA* each or one optional accessory with a maximum current consumption of 900 mA*. Switched via F1 .
X6	Optional accessory with a maximum current consumption of 500 mA*. Switched via F2 .
X7 und X8	Two optional accessories with a maximum current consumption of 500 mA* each or one optional accessory with a maximum current consumption of 900 mA*. Switched via F3 .
X9	Optional accessory with a maximum current consumption of 500 mA*. Switched via F4 or: Lighting for reverse direction (switched dependent of the direction of travel via F0).
X10	Optional accessory or lighting for forward direction with a maximum current consumption of 500 mA*. Switched dependent or independent of the direction of travel via F0).

* Maximum current consumption of all accessories = 1.500 mA

Technical specifications

Data format	DCC
Supply voltage	12-24 Volt digital voltage
Current consumption (without connected loads)	ca. 10 mA
Max. current per function output	500 mA
Max. total current	1.500 mA
Protected to	IP 00
Ambient temperature in use	0 - + 60° C
Ambient temperature in storage	-10 - + 80° C
Comparative humidity allowed	max. 85 %
Dimensions	ca. 12,5 x 27,5 x 3,5 mm
Weight	ca. 2 g

Checking the package contents

Check the contents of the package for completeness:

- 1 module
- 1 manual

Required tools and consumables

Make sure you have the following tools, equipment and materials ready for use:

- a heat-resistant mat
- a soldering iron stand with tip-cleaning sponge
- a small side cutter and wire stripper
- an electronic soldering iron (max. 30 Watt) with a fine tip
- tin solder (0,5 mm. diameter)
- wire (diameter: $\geq 0,08 \text{ mm}^2$ for all connections)

Safe and correct soldering



Caution:

Incorrect soldering can cause fires (through excessive heat). Avoid this danger by reading the chapter **Safety instructions** again and following the directions given.

If you have had training in soldering you can skip this chapter.

- When soldering electronic circuits never use soldering-water or soldering grease. They contain acids that can corrode components and copper tracks.
- Only use tin solder SN 60 Pb (i.e. 60 % tin, 40 % lead) with rosin-based flux.
- Use a small soldering iron with max. 30 Watt. Keep the soldering tip clean so the heat of the soldering iron is applied to the solder point effectively.
- Solder fast: long soldering can destroy components and copper tracks, and damages through plated holes.
- Apply the soldering tip to the soldering spot in such a way that the part and the soldering spot are heated at the same time. Simultaneously add solder (not too much). As soon as the solder becomes liquid take it away. Hold the soldering tip at the spot for a few seconds so that the tin solder finds its way, then remove the soldering iron.
- Do not move the component for about 5 seconds after soldering. A glossy and perfect soldering spot should remain.
- To make a good soldering joint you must use a clean and unoxidised soldering tip. Clean the soldering tip with a damp piece of cloth, a damp sponge or a piece of silicon cloth.

Performing a visual check

Damaged materials can cause injury. Parts damaged during transit can also be dangerous. Check the module for damage, missing parts or poor soldering. If you find damage, return the module for exchange.

Mounting the function decoder

Open the locomotive or the carriage housing. Locate the position for the decoder.

Follow the connections diagrams (fig. 1a and 1b)! Solder the connections to the rails at points X2 and X3.

Connecting the lighting and other accessories

Follow the connections diagrams (fig. 1a and 1b)!

Disconnect any existing diodes in the leads to the lamps. Connect the lamps for forward motion to X10 and - if desired - the lamps for reverse motion to point X9. If the lamps are already connected with one side to ground, you must solder in a diode between the decoder and the lamp (see fig. 1a) Otherwise you must connect the second side of the lamps according to fig. 1b to the return conductor (point X1).

Connect other accessories (e.g. smoke generator, noise module), which are switched by the functions F1 to F4, to the points X4 to X8. Connect the accessory which is switched via the function F2 to the point X6. The accessories connected to the points X4 and X5 resp. the points X7 and X8 are switched jointly on and off via the functions F1 resp. F3. If you want to connect an accessory with a current consumption of more than 500 mA you must connect the two outputs in parallel (fig. 1a and 1 b, connection to X4 and X5). You can connect a further accessory to point X9 which can be switched via the function F4 instead of the lighting for reverse direction.



Caution:

The current consumption of all connected accessories may not exceed 1.500 mA!

You can connect the second side of the accessories either to the return conductor (point X1) or to ground. If connecting the accessory to ground you must solder in a diode.

**Caution:**

The return conductor for all functions (point X1) must under no circumstances be connected to locomotive resp. carriage ground. Possible short circuit! The decoder will be damaged in operation.

**Caution:**

If you connect the loads to the return conductor for all functions (point X1), the loads must be insulated. The loads must not make contact with metal parts of the locomotive or the carriage. Possible short circuit! The decoder will be damaged in operation.

Connecting the LEDs

The function outputs of the decoder switch against decoder ground. For that reason you must connect the cathode (-) of the LED to the output of the relevant function.

**Caution:**

If you use light-emitting diodes (LEDs) you must always operate them via a series resistor.

LEDs are available in many different models. There are LEDs with 2-5 mA, but also LEDs with 15-30 mA power consumption. The series resistor limits the current flow of the LED and will need to be calculated for each model. Ask for the max current rating when buying your LEDs.

You can connect several LEDs in parallel to each output. In this case every LED must have a series resistor of its own. If you connect several LEDs to one output in series, only one series resistor is needed. The number of LEDs connected in series to one output depends on the digital voltage.

You can determine the number of the LEDs that can be connected in series to one output from the following formula:

$$\boxed{(\text{number of LEDs} + 2) \times 1,5 < \text{digital voltage}}$$

Fixing the decoder

After completing all connections fix the decoder with double-sided adhesive tape, for example.

Programming the function decoder

The function decoder is programmed from the digital control unit. See chapter in the manual of your digital control unit where the programming of configuration variables (CVs) is explained.

You can programm the following function decoder variables:

CV-Name	CV-Nr.	Eingabewert (Auslieferungszustand)	Erläuterungen
Basic address	1	1 ... 127 (3)	
Consist-address	19	1 ... 127 (0)	= 2nd address
Configuration data	29	0,1,2 or 3 (2)	This data is set by entering the sum of the numerical values. Numerical value direction "standard" 0 invert direction 1 14 speed levels 0 28 speed levels 2
Utilization and setting of output X9 and X10	56	0,1,2 or 3 (3)	This data is set by entering the sum of the numerical values. Numerical value Constant lighting 0 Lighting according to direction of travel 1 Optional accessory switched via F4 0 Lighting for reverse direction 2

FAQ

- Parts are getting too hot and/or start to smoke.
 **Disconnect the module from the mains immediately!**
Possible cause: Short circuit. The decoder is connected to locomotive or carriage ground.
→ Check the connections. A short circuit can result in irreparable damage.
- The lighting does not correspond to the direction of travel.
Possible cause: The configuration data (CV29) of the locomotive decoder in the train vary from the configuration data programmed in the function decoder.
→ Change the programming or the function or the locomotive decoder.
- The lighting for forward direction cannot be switched via F0.
Possible cause: The speed mode of the decoder and the digital control unit do not correspond. Example: The control unit is set to the mode 28 speed levels, but the decoder to the mode 14 speed levels.
→ Change the speed mode at the control unit and / or at the decoder.

If you cannot find the problem, please return the decoder for repair (address on the cover page).

Manufacturer's note

According to DIN VDE 0869, the person who builds this kit or brings the circuit into operation is the manufacturer of the product. If he sells the product to another person he is responsible for passing on all the relevant papers. Domestic appliances assembled from a kit are deemed industrial products and must comply with health and safety regulations.

Certification

This product conforms with the EC- directive 89/336/EWG on electromagnetic radiation and is therefore CE certified.

Conditional warranty

This product is guaranteed for two years. The warranty includes free repair if the problem is due to material failure or incorrect assembly of the module by us. We guarantee the quality of the components.

Other claims are excluded. By law, we are not responsible for damages or secondary damages in connection with this product. We retain the right to repair, make improvements, supply spare parts or return the purchase price.

The following invalidate the warranty:

- using an unsuitable soldering iron, solder containing liquid acids or similar,
- if damage is caused by not following the instructions in this manual or the circuit diagram,
- if the circuit has been altered and repair attempts have failed,
- if arbitrary changes in the circuit are made,
- if parts are stored incorrectly and if the wires to the switches, the power resistors, etc. are made incorrectly,
- if the copper tracks or soldering points are damaged,
- if damage occurs due to an overload of the circuit,
- if the wrong power or current is connected,
- if damaged by other persons,
- if damaged by the wrong use or abuse of the circuit,
- if parts are damaged due to static because they were touched before a discharge is performed.

Anschlußplan - Connections diagram - Schema de connexion - Aansluit plan

■ ■ ■ Fig. 1

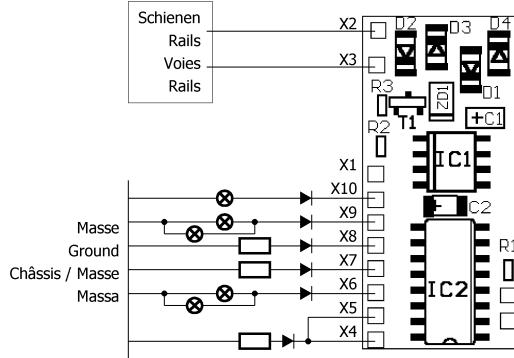

Fig. 1a:

Verbindung des 2. Anschlusses mit Masse
 Connection of the 2nd side to ground
 Raccordement des fonctions via le châssis / masse
 Verbinding van de 2e aansluiting met de massa

➔ Diode 1N4007 oder ähnlich /
 or similar / ou similaire /
 of gelijkwaardig

☐ Beliebiges Verbraucher
 (z.B. Rauchgenerator,
 Führerstandsbeleuchtung,
 Geräuschmodul)
 Optional accessories
 (e.g. smoke generator,
 cab lighting, noise module)
 Consommateurs divers
 (par ex. fumigène, éclairage
 cabine, module sonore)
 Willekeurige verbruiker
 (b.v. rookgenerator,
 machinistenhuisverlichting,
 geluidsmodule)

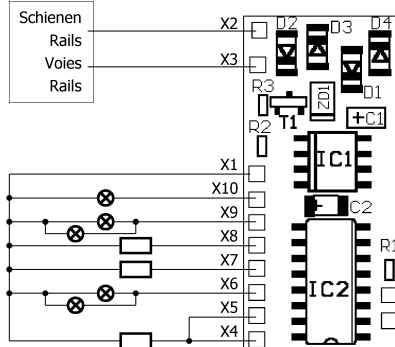

Fig. 1b:

Anschluß bei Verwendung des Rückleiters X1
 Connection when using the return conductor X1
 Raccordement des fonctions vi la borne commune X1
 Aansluiten bij gebruik van de retourleiding X1

X2/X3	Schienen / Rails Voies / Rails
X1	Rückleiter für alle Funktionen Return conductor for all functions Retour pour toutes les fonctions Retourdraad voor alle functies
X10	F0 (Licht) F0 (Light) F0 (Eclairage) F0 (Licht)
X9	F4
X7/X8	F3
X6	F2
X4/X5	F1

Schaltplan - Circuit diagram - Schéma de commutation - Schakelplan

■ ■ ■ Fig. 2

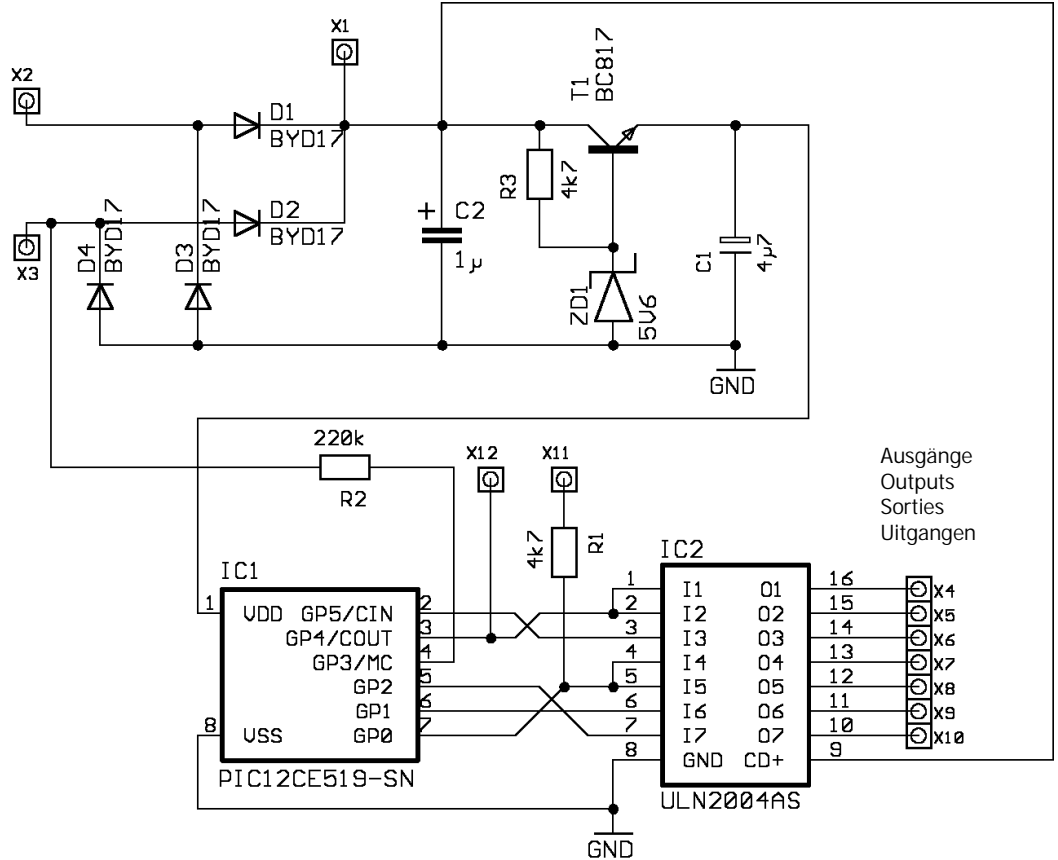

Ausgänge
Outputs
Sorties
Uitgangen

Aktuelle Informationen und Tipps:

Information and tips:

Informations et conseils:

Actuele informatie en tips:

<http://www.tams-online.de>

Garantie und Service:

Warranty and service:

Garantie et service:

Garantie en service:

Tams Elektronik GmbH

Rupsteinstraße 10

D-30625 Hannover

fon: 0049 (0)511 / 55 60 60

fax: 0049 (0)511 / 55 61 61

e-mail: modellbahn@tams-online.de