

GBM-1

Gleisbesetzmelder

Track Busy Indicator

Indicateur d'occupation

Railbezetmelder



Anleitung

Manual

Mode d'emploi

Handleiding

Art.-Nr. 21-01-026 / 22-01-026



© 08/2004 Tams Elektronik GmbH

Alle Rechte, insbesondere das Recht der Vervielfältigung und Verbreitung sowie der Übersetzung vorbehalten. Vervielfältigungen und Reproduktionen in jeglicher Form bedürfen der schriftlichen Genehmigung durch die Tams Elektronik GmbH.

Technische Änderungen vorbehalten.

■

■

■

■ **Deutsch** **3**

■ **English** **20**

■ **Français** **35**

■ **Nederlands** **51**

■

■

■

■

■

■

■

■

■

© 08/2004 Tams Elektronik GmbH

All rights reserved. No part of this publication may be reproduced or transmitted in any form or by any means, electronic or mechanical, including photocopying, without prior permission in writing from Tams Elektronik GmbH.

Subject to technical modification.

© 08/2004 Tams Elektronik GmbH

Tout droits réservés, en particulier les droits de reproduction et de diffusion ainsi que le traduction. Toute duplication ou reproduction sous quelque forme que ce soit nécessite l'accord écrit de la société Tams Elektronik GmbH.

Sous réserve de modifications techniques.

© 08/2004 Tams Elektronik GmbH

Alle rechten voorbehouden. Niets uit deze publicatie mag worden vernenigvuldigd opgeslagen of openbaar gemaakt, zonder voorafgaande schriftelijke toestemming van Tams Elektronik GmbH.

Technische wijzigingen voorbehouden.

Table of contents

How to use this manual	21
Intended use	21
Safety instructions	22
EMC declaration	24
Operation overview	24
Technical specifications	25
Checking the package contents	25
Required tools and materials	25
Safe and correct soldering	26
Assembling the kit	27
Performing a visual check	30
Performing a functional test	31
Connecting the track busy indicator	32
FAQ	33
Manufacturer's note	33
Certification	33
Conditional warranty	34
Parts list	I.1
Printed Circuit Board (PCB) layout (Fig. 1)	I.2
Circuit Diagram (Fig. 2)	II
Connections (Fig. 3)	III
(Pages I to III in the centre of this handbook are removeable.)	

How to use this manual

If you have no specialist technical training, this manual gives step-by-step instructions for safe and correct assembly of the kit and fitting of the ready-built module, and operation. Before you start, we advise you to read the whole manual, particularly the chapter on safety instructions and the FAQ chapter. You will then know where to take care and how to prevent mistakes which take a lot of effort to correct.

Keep this manual safely so that you can solve problems in the future. If you pass the kit or the ready-built module on to another person, please pass on the manual with it.

Intended use



Caution:

Integrated circuits are very sensitive to static electricity. Do not touch components without first discharging yourself. Touching a radiator or other grounded metal part will discharge you.

The kit or the ready-built module can be assembled or operated using this manual. The ready-built module is designed for use in model railways. It indicates occupied tracks on four independent track sections.

The kit and the ready-built module should not be assembled or fitted by children under the age of 14.

Reading, understanding and following the instructions in this manual are mandatory for the user.

Any other use is inappropriate and invalidates any guarantees.

Safety instructions

Mechanical hazards

Cut wires can have sharp ends and can cause serious injuries. Watch out for sharp edges when you pick up the PCB.

Visibly damaged parts can cause unpredictable danger. Do not use damaged parts: recycle and replace them with new ones.

Electrical hazards

- Touching powered, live components,
- touching conducting components which are live due to malfunction,
- short circuits,
- connecting the circuit to another voltage than specified,
- impermissibly high humidity,
- condensation build up

can cause serious injury due to electrical shock. Take the following precautions to prevent this danger:

- Never perform wiring on a powered module.
- Assembling and mounting the kit should only be done in closed, clean, dry rooms. Beware of humidity.
- Only use low power for this module as described in this manual and only use certified transformers.
- Connect transformers and soldering irons only in approved mains sockets installed by an authorised electrician.
- Observe cable diameter requirements.
- After condensation build up, allow a minimum of 2 hours for dispersion.
- Use only original spare parts if you have to repair the kit or the ready-built module.

Fire risk

Touching flammable material with a hot soldering iron can cause fire, which can result in injury or death through burns or suffocation. Connect your soldering iron or soldering station only when actually needed. Always keep the soldering iron away from inflammable materials. Use a suitable soldering iron stand. Never leave a hot soldering iron or station unattended.

Thermal danger

A hot soldering iron or liquid solder accidentally touching your skin can cause skin burns. As a precaution:

- use a heat-resistant mat during soldering,
- always put the hot soldering iron in the soldering iron stand,
- point the soldering iron tip carefully when soldering, and
- remove liquid solder with a thick wet rag or wet sponge from the soldering tip.

Dangerous environments

A working area that is too small or cramped is unsuitable and can cause accidents, fires and injury. Prevent this by working in a clean, dry room with enough freedom of movement.

Other dangers

Children can cause any of the accidents mentioned above because they are inattentive and not responsible enough. Children under the age of 14 should not be allowed to work with this kit or the ready-built module.

Little children can swallow small components with sharp edges, with fatal results! Do not allow components to reach small children.

In schools, training centres, clubs and workshops, assembly must be supervised by qualified personnel.

In industrial institutions, health and safety regulations applying to electronic work must be adhered to.

EMC declaration

This product is developed in accordance with the European standards EN 55014 and EN 50082-1, tested corresponding to the EC - directive 89/336/EEG (EMVG of 09/11/1992, electromagnetic tolerance) and meets legal requirements.

To guarantee the electromagnetic tolerance you must take the following precautions:

- Connect the transformer only to an approved mains socket installed by an authorised electrician.
- Make no changes to the original parts and accurately follow the instructions, circuit diagram and PCB layout included with this manual.
- Use only original spare parts if you have to repair the kit or the ready-built module.

Operation overview

The module indicates occupied tracks on four independent track sections. It can be used universally in all systems (d.c. voltage, a.c. voltage and digital systems).

It is connected between the analogue transformer or the digital central and the chosen track section and monitors all connected loads (e.g. engines or carriages with lighting) located on the track section concerned. Carriages without lighting running on a two-rail system turn into connected loads if the axle is painted with conducting varnish. Connected electrical loads located in a switched-off track section can be detected if an additional resistor is inserted.

Detection is made against ground. Very small currents are sufficient. Digital check-back decoders can be connected directly to the outputs of the module.

Technical specifications

Supply voltage	12-18 Volt a.c. voltage
Current consumption (without connected loads)	approx. 15 mA
Max. current per output	250 mA
Protected to	IP 00
Ambient temperature in use	0 - + 60 °C
Ambient temperature in storage	-10 - + 80 °C
Comparative humidity allowed	max. 85 %
Dimensions	approx. 73 x 80 mm
Weight	approx. 49 g

Checking the package contents

Check the contents of the package for completeness immediately after unpacking:

- one kit, containing the components listed in the parts list (see page I) and one PCB or
- one ready-built module,
- one manual.

Required tools and materials

Make sure you have the following tools, equipment and materials ready for use:

- an electronic soldering iron (max. 30 Watt) with a fine tip,
- a soldering iron stand,
- a tip-cleaning sponge,
- a heat-resistant mat,
- a small side cutter and wire stripper,
- tin solder (0,5 mm. diameter),
- wire (diameter: $\geq 0,22 \text{ mm}^2$ for all connections),

- a pair of tweezers and long nose pliers (not necessary for the ready-built module),
- a lamp or bulb for the functional test.

Safe and correct soldering

Caution:

Incorrect soldering can cause dangers through fires and heat. Avoid these dangers by reading and following the directions given in the chapter **Safety instructions**. If you have had training in soldering you can skip this chapter.

- Use a small soldering iron with max. 30 Watt. Keep the soldering tip clean so the heat of the soldering iron is applied to the solder point effectively.
- Only use tin solder SN 60 Pb (i.e. 60 % tin, 40 % lead) with rosin-based flux.
- When soldering electronic circuits never use soldering-water or soldering grease. They contain acids that can corrode components and copper tracks.
- Solder quickly: holding the iron on the joints longer than necessary can destroy components and can damage copper tracks or soldering eyes.
- Observe correct polarity orientation of semi-conductors, LEDs electrolytic capacitors and integrated circuits before soldering and ensure that the solder time does not exceed 5 seconds, otherwise components can be damaged.
- Apply the soldering tip to the soldering spot in such a way that the part and the soldering eye are heated at the same time. Simultaneously add solder (not too much). As soon as the solder becomes liquid take it away. Hold the soldering tip at the spot for a few seconds so that the solder flows into the joint, then remove the soldering iron.
- Do not move the component for about 5 seconds after soldering. A glossy and perfect soldering spot should remain.

- To make a good soldering joint you must use a clean and unoxidised soldering tip. Clean the soldering tip with a damp piece of cloth, a damp sponge or a piece of silicon cloth.
- Cut the wires after soldering directly above the PCB solder side with a side cutter.
- After placing the parts, please double check for correct polarity. Check the PCB tracks for solder bridges and short circuits created by accident. This would cause faulty operation or, in the worst case, damage. You can remove excess solder by putting a clean soldering tip on the spot. The solder will become liquid again and flow from the soldering spot to the soldering tip.

Assembling the kit

You can skip this part if you have purchased a ready-built module.

Preparation

Put the sorted components in front of you on your workbench. The separate electronic components have the following special features you should take into account to prevent mistakes in assembling:

Resistors

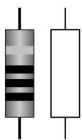

Resistors reduce current. Their mounting orientation is of no importance. The value of resistors for smaller power ratings (under 5 W) is indicated through colour rings. Every colour stands for another figure.

Value	Colour rings
470 Ω	yellow - violet - brown (gold)
1,5 k Ω	brown - green - red (gold)
10 k Ω	brown - black - orange (gold)
47 k Ω	yellow - violet - orange (gold)
470 k Ω	yellow - violet - yellow (gold)

The colour ring in brackets indicates the tolerance of the resistor which here is of no importance.

Capacitors



Among other things capacitors are used for filtering interference voltages or as frequency determining parts. Ceramic capacitors are not polarized, for that reason their mounting orientation is of no importance. Normally they are marked with a three-digit number which indicates the value coded.

Value	Number
100 nF	104

Electrolytic capacitors

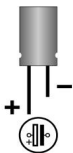

Electrolytic capacitors are often used to store energy. In contrast to ceramic capacitors they are polarized. One of the two leads is marked with a minus sign which indicates the mounting orientation. The value is given on the casing.

Electrolytic capacitors are available with different voltage sustaining capabilities. Using an electrolytic capacitor with a voltage sustaining capability higher than required is always possible.

Diodes

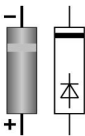

Diodes allow the current to pass through in one direction only (forward direction), simultaneously the voltage is reduced by 0,3 to 0,8 V. Exceeding of the limit voltage always will destroy the diode, and allow current to flow in the reverse direction.

The diode type is printed on the body.

Diodes must be mounted in a given direction. The negative end is marked with a ring. This is shown in the PCB layout.

Zener diodes

Zener diodes are used for limiting voltages. In contrast to „normal“ diodes they are not destroyed when the limit voltage is exceeded.

Light emitting diodes (LEDs)



When operated in the forward direction the LEDs light. They are available in several different versions (differing in colour, size, form, luminosity, maximum current, voltage limits). The longer lead of wired LEDs is always the anode (positive pole).

Light emitting diodes should always be connected via a series resistor which limits the current and prevents failure.

Transistors



Transistors are current amplifiers which convert low signals into stronger ones. They have three contacts. As they are polarized, they have to be mounted in a certain direction.

The BD types have a flat housing (TO-housing) with the type designation printed on the front side. The metallic rear is unlabelled, on the PCB layout the rear is marked by a thick line.

Integrated circuits (ICs)

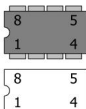

Depending on the type, ICs fulfil various tasks. They are polarized and therefore have to be mounted in a certain direction. The most common housing form is the so-called "DIL"-housing, from which 4, 6, 8, 14, 16, 18 or more "legs" (pins) are arranged along the long sides. The mounting orientation is shown by a semicircular or circular marking at the end of the housing, which is also shown on the PCB layout.

ICs are sensitive to damage during soldering (heat, electrostatic charging). For that reason in the place of the ICs IC sockets are soldered in, in which the ICs are inserted later. The mounting orientation of the sockets is preset as well. The markings on the PCB, the socket and the IC must lie on top of each other after mounting.

Terminal strips

Terminal strips are solder-in screw-type terminals. They provide a solder-free and safe connection of the cables to the circuit, which can still be separated any time. When several terminal strips have to be mounted side by side, they have to be put together before mounting.

Assembling the kit

Start the assembly with the resistors. First solder the components on the solder side of the PCB and then cut the excess wires with the side cutter, as short as possible. Insert the wire bridges Br1 and Br2. Use the off-cut wires of the resistors.

Continue the assembly with the diodes. Then insert and solder in the IC-socket, the capacitors, the LEDs and the transistors.



Caution:

Diodes, ICs, electrolytic capacitors and transistors must be placed in the right direction! If you solder them the wrong way the affected parts can be damaged when you connect the power. In the worst case the whole circuit can be damaged. In any case, a wrongly connected part will not function.

Next solder in the terminal strips. Put together the terminal strips before mounting them. Finally, insert the IC into the soldered IC-socket.



Caution:

Do not touch the ICs without first discharging yourself by touching a radiator or other grounded metal parts. Do not bend the "legs" of the ICs when inserting them into the sockets. Check that the markings on the PCB, the socket and the IC show to the same direction.

Performing a visual check

Due to material defects and/or improper assembly there may be risks of injury. Transport damage to ready-built modules is also possible. So you must perform a visual check after the assembly or after unpacking the module.

**Caution:**

Do not power up the module yet.

Check all nuts, pins and connections as well as the mechanical connections for correct assembly.

The following points are inapplicable if you have purchased a ready-built module.

- Remove all loose parts, wire ends or drops of solder from the PCB. Remove all sharp wire ends.
- Check that solder contacts which are close to each other are not unintentionally connected to each other. Risk of short circuit!
- Check that all components are polarised correctly.

When you have remedied all faults, go on to the next part.

Performing a functional test

Even if you have purchased a ready-built module, check all functions. Transport damage can never be excluded.

**Caution:**

Do not connect the module to the power supply yet.

Check the functions of the module with a test lamp or bulb. Connect the four functional sections of the track-busy indicator one after the other with the lamp. Proceed as follows:

There are terminal strips soldered to the in- and outputs. Insert the connecting cables into the relevant terminals and fasten the screws.

First connect the test lamp with the input E1 and the voltage supply "~" of the track busy indicator (not with earth!). Connect the module to the transformer. Follow fig. 3 "connections". Connect the transformer to the mains.

The test lamp and the LED at output A1 should now light. Disconnect the test lamp from input E1. The LED at output A1 should go off.

Repeat the test with the other three functional sections of the track-busy indicator.

! Caution:

If a component gets too hot, disconnect the booster and transformer from the mains immediately. Possible short circuit! Check the assembly again.

After performing a successful function test, disconnect the track busy indicator from the voltage supply and continue with the connection of the module.

Connecting the track busy indicator

Follow the connections diagram fig. 3. First connect the inputs E1 to E4 with the mass connection of the four track sections to be monitored. Next connect the power supply cables of the track-busy indicator to the transformer. If not already done, connect ground of the light transformer with ground of the driving transformer.

! Caution:

The ground of the driving transformer must not be connected to any of the four track sections to be monitored.

You can now connect lamps, LEDs or relays directly to the outputs of the track-busy indicator. As the outputs switch against ground, it is also possible to connect digital check-back decoders. In this case follow the manual for the decoder concerned.

Monitoring of cut off track sections

Track sections to be cut off in operation (e.g. in a shadow station) can also be monitored with the track busy indicator. For that purpose a resistor with a value between 1 k Ω und 4,7 k Ω has to be mounted in the wire leading to the concerned track section so that it shunts the switch when the track section is cut off (s. fig. 3 connection to E4).

FAQ

- Parts are getting too hot and/or start to smoke.
 **Disconnect the system from the mains immediately!**
Possible cause: one or more components are soldered incorrectly.
→ Perform a visual check.
- The lamps connected to the module do not light.
Possible cause: The voltage supply has been interrupted.
→ Check the connection from the module to the transformer.
Possible cause: One or more lamps are defective.
→ Check the lamps by connecting them directly to the power supply.
Possible cause: The diode D1 is soldered in the wrong direction.
→ Change the direction!
- A feedback module connected in series (e.g. s88-feedback module) does not work reliably.
Possible cause: The LEDs of the track busy indicator create external voltages which affect the digital feedback module.
→ Demount the LEDs from the track busy indicator.

If you cannot find the problem, please return the module for repair (address on the cover page).

Manufacturer's note

According to DIN VDE 0869, the person who builds this kit or brings the circuit into operation is the manufacturer of the product. If he sells the product to another person he is responsible for passing on all the relevant papers. Domestic appliances assembled from a kit are deemed industrial products and must comply with health and safety regulations.

Certification

This product conforms with the EC- directive 89/336/EWG on electromagnetic radiation and is therefore CE certified.

Conditions of warranty

This product is guaranteed for two years. The warranty includes the correction of faults which can be proved to be due to material failure or factory flaw. As we have no control over the correct and proper assembly and mounting we can only guarantee the quality of the components and the completeness of kits. We guarantee the function of the parts according to the parameters in not mounted state as well as the adherence to the technical specifications of the circuit when assembled and connected according to the manual.

Other claims are excluded. By law, we are not responsible for damages or secondary damages in connection with this product. We retain the right to repair, make improvements, supply spare parts or return the purchase price.

The following invalidate the warranty:

- using an unsuitable soldering iron, solder containing liquid acids or similar,
- if the kit is assembled and soldered poorly, or if damage is caused by not following the instructions in this manual,
- if the ready-built module has been altered and repair attempts have failed,
- if arbitrary changes in the circuit are made,
- if the circuitry is changed in any way, through adding or omitting wiring or components, or through modifying the circuit board,
- if parts other than the original ones delivered with this kit are used,
- if the copper tracks or soldering eyes are damaged,
- when components are mounted incorrectly, or if the components or the circuit are poled incorrectly, also subsequent damage resulting from these faults,
- if damage occurs due to an overload of the module,
- if connected to a incorrect voltage or current,
- if damaged by other persons,
- if damaged by faulty operation or if damaged by careless use or abuse,
- if damaged by touching components before electrostatic discharging of the hands.

Stückliste - Parts list

Nomenclature - Stuklijst

Widerstände Resistors Résistances Weerstanden	R1	470 Ω
	R4, R7, R10, R13, R14, R16, R18, R20	10 k Ω
	R2, R3, R5, R6, R8, R9, R11, R12	470 k Ω
	R15, R17, R19, R21	47 k Ω
	R22 - R26	1,5 k Ω
Kondensatoren - Condensers Condensateurs - Condensatoren	C1 - C8	100 nF
	C9, C10	220 μ F \geq 25 V
	C11 - C14	22 μ F \geq 16 V
Dioden - Diodes	D1	1N5400 *
	D2 - D26	1N4148 *
	D33 - D40	1N4004 *
Zener-Dioden - Zener diodes Diodes Zener - Zenerdiodes	D27	ZD 12 V *
LEDs - LEDs - DEL - LEDs	D28-D31	rot - red rouge - rood
	D32	grün - green vert - groen
Transistoren - Transistors	T1 - T4	BD679
IC - CI	IC1	LM 339 N
IC-Sockel - IC-socket Soquet CI - IC-voetje	1 x	14-pol.
Anreihklemme - Terminal strips Borniers - Aansluitklemmen	X1 - X3	4 x 3-pol.

* oder ähnlich - or similar - ou équivalent - of gelijkwaardig

Fig. 1: Bestückungsplan - PCB layout
Plan d'implantation - Printplan

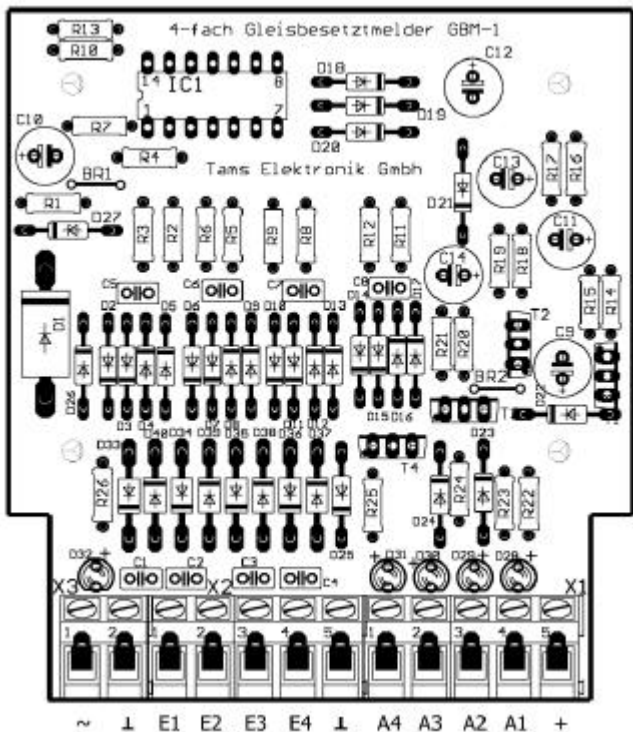

Fig. 2:
Schaltplan
Circuit Diagram
Schéma de principe
Schakelplan

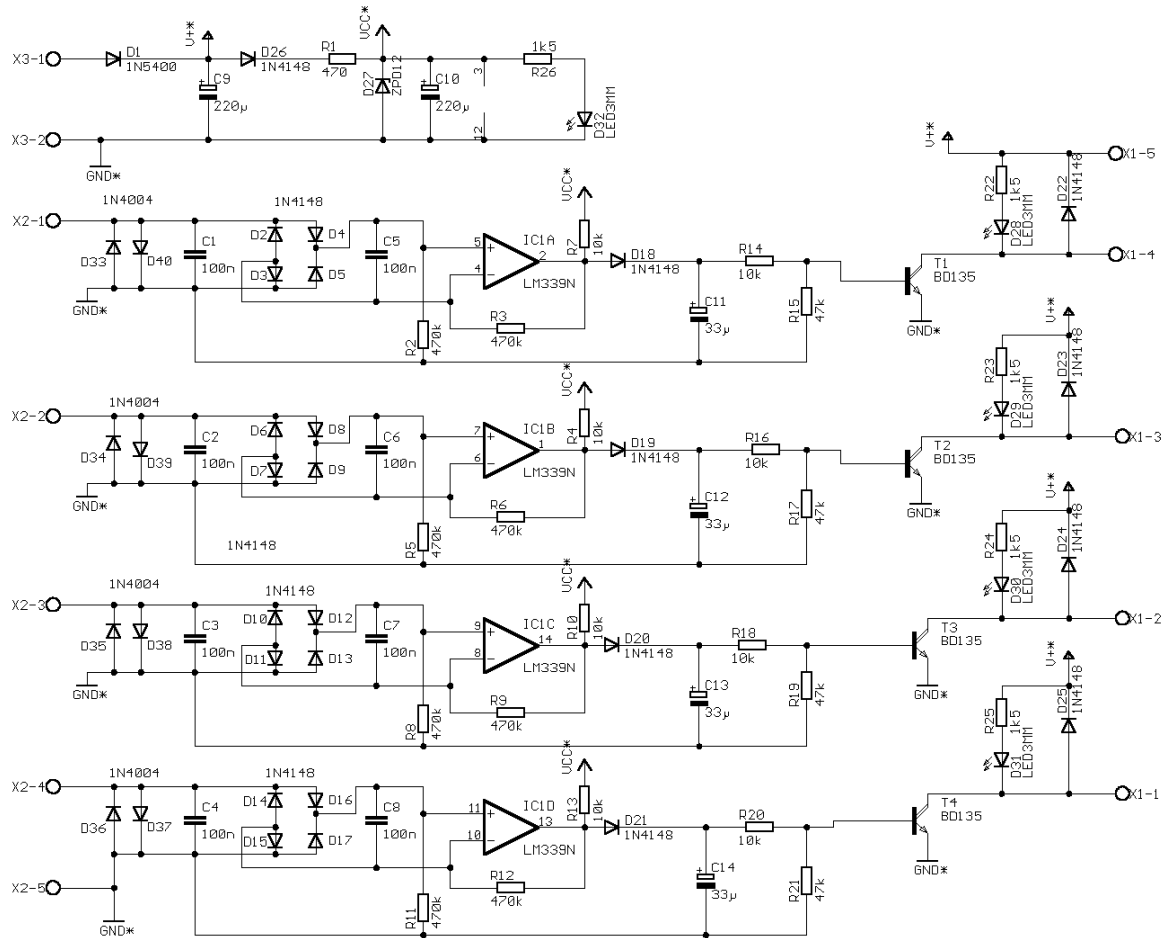
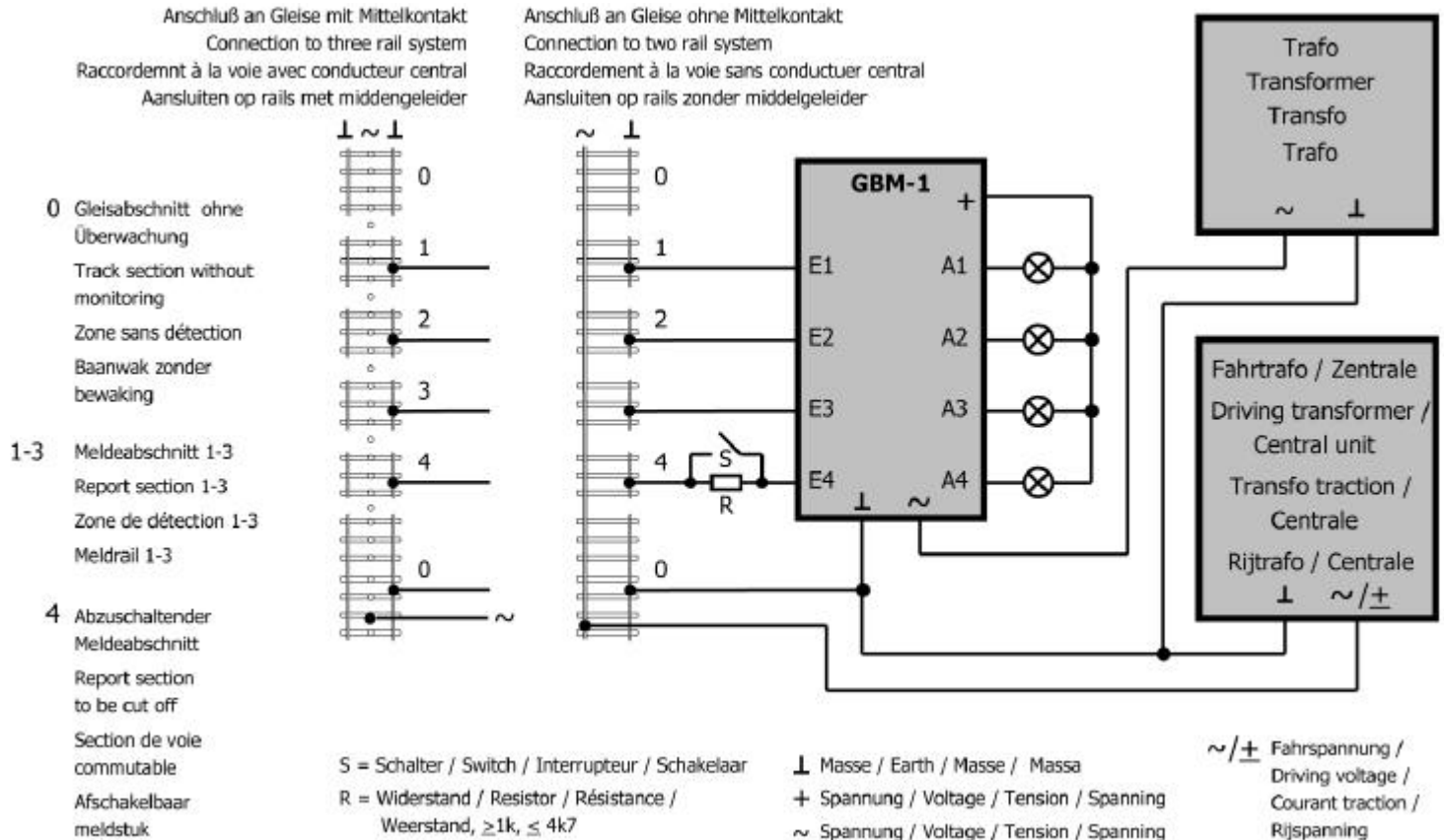

Fig. 3: Anschlußplan - Connection Diagram - Plan de connexion - Aansluitplan



Aktuelle Informationen und Tipps:

Information and tips:

Informations et conseils:

Actuele informatie en tips:

<http://www.tams-online.de>

Garantie und Service:

Warranty and service:

Garantie et service:

Garantie en service:

Tams Elektronik GmbH

Rupsteinstraße 10

D-30625 Hannover

fon: +49 (0)511 / 55 60 60

fax: +49 (0)511 / 55 61 61

e-mail: modellbahn@tams-online.de