

LD-W-1

Lokdecoder für Wechselstrommotoren

Motorola-Format

Locomotive Decoder for AC engines

Motorola-Format

Décodeur pour locomotive avec moteur alternatif

Format-Motorola

Locdecoder voor wisselstroommotoren

Motorola-format

Art.-Nr. 22-01-015-3



LD-G-1

Lokdecoder für Gleichstrommotoren

Motorola-Format

Locomotive Decoder for DC engines

Motorola-Format

Décodeur pour locomotive avec moteur continu

Format-Motorola

Locdecoder voor gelijkstroommotoren

Motorola-format

Art.-Nr. 22-01-016-3

Anleitung

Manual

Mode d'emploi

Handleiding



Table of contents

| | |
|--|-----|
| How to use this manual | 32 |
| Intended use | 32 |
| Safety instructions | 32 |
| EMC declaration | 34 |
| Operation overview | 35 |
| Technical specifications | 38 |
| Checking the package contents | 38 |
| Required tools and materials | 39 |
| Safe and correct soldering | 39 |
| Mounting the locomotive decoder | 40 |
| Setting the address via solder bridges | 43 |
| Programming the locomotive decoder | 43 |
| Operation | 54 |
| FAQ | 55 |
| Manufacturer's note | 55 |
| Certification | 56 |
| Conditional warranty | 56 |
| Appendix: Check back of the address | 112 |
| Connections (Fig. 1 and Fig. 2) | I |
| Circuit Diagram (Fig. 3) | III |

(Pages I to III in the centre of this handbook are removeable.)

* **"Märklin"** is a registered and protected trade mark of Gebr. Märklin & Co, Stuttgarter Straße, Göppingen, Germany.

** **"Intellibox"** is a registered and protected trade mark of Uhlenbrock Elektronik GmbH, Bottrop, Germany.

How to use this manual

If you have no specialist technical training, this manual gives step-by-step instructions for safe and correct fitting of the module, and operation. Before you start, we advise you to read the whole manual, particularly the chapter on safety instructions and the FAQ chapter. You will then know where to take care and how to prevent mistakes which take a lot of effort to correct.

Keep this manual safely so that you can solve problems in the future. If you pass the module on to another person, please pass on the manual with it.

Intended use

Caution:

Integrated circuits are very sensitive to static electricity. Do not touch components without first discharging yourself. Touching a radiator or other grounded metal part will discharge you.

The module can be used according to the specifications of this manual in a model railway locomotive with d.c. motor (LD-G-1) resp. a.c. motor (LD-W-1). It evaluates the Motorola II format data sent by the digital central unit to its address. The decoder controls the vehicle performance (velocity, direction of travel, acceleration) and switches seven function outputs.

The module is not suitable for children under the age of 14. Reading, understanding and following the instructions in this manual are mandatory for the user. Any other use is inappropriate and invalidates any guarantees.

Safety instructions

Mechanical hazards

Cut wires can have sharp ends and can cause serious injuries. Watch out for sharp edges when you pick up the PCB.

Visibly damaged parts can cause unpredictable danger. Do not use damaged parts: recycle and replace them with new ones.

Electrical hazards

- Touching powered, live components,
- touching conducting components which are live due to malfunction,
- short circuits,
- connecting the circuit to another voltage than specified,
- impermissibly high humidity,
- condensation build up

can cause serious injury due to electrical shock. Take the following precautions to prevent this danger:

- Never perform wiring on a powered module.
- Mounting the module should only be done in closed, clean, dry rooms. Beware of humidity.
- Only use low power for this module as described in this manual and only use certified transformers.
- Connect transformers and soldering irons only in approved mains sockets installed by an authorised electrician.
- Observe cable diameter requirements.
- After condensation build up, allow a minimum of 2 hours for dispersion.
- Use only original spare parts if you have to repair the module.

Fire risk

Touching flammable material with a hot soldering iron can cause fire, which can result in injury or death through burns or suffocation. Connect your soldering iron or soldering station only when actually needed. Always keep the soldering iron away from inflammable materials. Use a suitable soldering iron stand. Never leave a hot soldering iron or station unattended.

Thermal danger

A hot soldering iron or liquid solder accidentally touching your skin can cause skin burns. As a precaution:

- use a heat-resistant mat during soldering,
- always put the hot soldering iron in the soldering iron stand,
- point the soldering iron tip carefully when soldering, and

- remove liquid solder with a thick wet rag or wet sponge from the soldering tip.

Dangerous environments

A working area that is too small or cramped is unsuitable and can cause accidents, fires and injury. Prevent this by working in a clean, dry room with enough freedom of movement.

Other dangers

Children can cause any of the accidents mentioned above because they are inattentive and not responsible enough. Children under the age of 14 should not be allowed to work with this module.

Little children can swallow small components with sharp edges, with fatal results! Do not allow components to reach small children.

Do not allow components to reach small children.

In schools, training centres, clubs and workshops, assembly must be supervised by qualified personnel.

In industrial institutions, health and safety regulations applying to electronic work must be adhered to.

EMC declaration

This product is developed in accordance with the European standards EN 55014 and EN 50082-1, tested corresponding to the EC - directive 89/336/EWG (EMVG of 09/11/1992, electromagnetic tolerance) and meets legal requirements.

To guarantee the electromagnetic tolerance you must take the following precautions:

- Connect the transformer only to an approved mains socket installed by an authorised electrician.
- Make no changes to the original parts and accurately follow the instructions, circuit diagram and connections diagrams included with this manual.
- Use only original spare parts if you have to repair the module.

Operation overview

The decoder is designed for operation in Motorola II format and can be adjusted to one of 255 addresses. It evaluates the digital data sent by the central unit to its address and transmits it to the locomotive.

In Motorola I format it is possible to operate the decoder, but the programming of the parameters and the controlling of the functions is restricted.

Function speed level and direction of motion

The speed level set at the central unit and the change-direction command are transmitted to the locomotive by the decoder. At a direction change command, the current direction of travel is saved.

Velocity characteristic

The decoder can be adjusted to the individual driving characteristics of the motor and the characteristic speed of the locomotive type, by setting the starting velocity and the maximum velocity. From the starting velocity and the maximum velocity the decoder generates a velocity characteristic corresponding to the opposite figure. This characteristic allows a good fine tuning of the speed in the lower speed range.

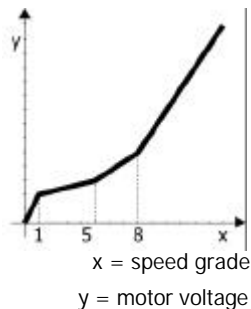

Second velocity characteristic

It is possible to program a second velocity characteristic (e.g. for shunting operation). You can switch between the two velocity characteristics by operating the function key F4.

Acceleration and brake delay

It is possible to program the acceleration and brake delay individually via the central unit. When the function F4 is switched on, the

acceleration and brake delay is deactivated (and simultaneously it switches over to the second velocity characteristic). Even if the acceleration and the brake delay are active you can actuate an emergency stop via the central unit by reversing the direction of travel.

Automatic shuttle service

If the automatic shuttle service is active the locomotive stops with the set brake delay as soon as the decoder detects a negative direct voltage on the track (Märklin* braking route). Then the decoder changes internally the directions of motion „forwards“ and „backwards“. After the negative direct voltage on the track has been compensated the locomotive automatically starts with the set acceleration delay in the opposite direction.

During standard operation it is possible to drive the decoder as usual even if the automatic shuttle service is active. While the standard operation is interrupted the decoder maintains it's present direction of travel.

Function outputs

The decoder has seven function outputs which can be switched on and off via the function keys „function“ and / or the auxiliary function keys F1 to F4. They are available to connect optional accessories (e.g. lighting, smoke generator, sound module, electric coupling).

The set states of the function outputs are saved. Even if the decoder is without current for a longer time, the states are set when the decoder is switched on again.

Assignment: The outputs X7 to X10 are assigned to the function outputs F1 to F4. You can assign the function keys to the function outputs X4 to X6 freely. It is possible to assign several function keys to these function outputs. Function outputs that are assigned to the function key „function“ can be switched according to the direction of travel.

Example of use: The lighting of a shunting locomotive is assigned both to the function key „function“ as to the function key F4. In shunting operation you switch the lighting via F4 and in standard operation according to the direction on travel via „function“.

Dimming: The function outputs X4 to X6 can be dimmed individually.

Example of use: The electric bulbs of older locomotives made for analogue operation can be dimmed and thus must not be exchanged after the mounting of the decoder.

Example of use: The front lighting is assigned to two different function outputs. Via one function key you can switch the standard lighting, via another the long distance lighting.

Check back of the address

In the programming mode you can query the address. The address is transmitted coded by the flashing of the lighting of the locomotive.

Online-programming

The address, the driving characteristics and all functions can be programmed online. This means:

- In order to start the programming mode and to set the desired (new) address, it is not necessary to enter the present address.
- While programming the driving characteristics (starting and maximum velocity, acceleration and brake delay) the locomotive is running. By operating the speed knob the driving characteristics are altered. As soon as these are set as desired, they can be saved directly (online).
- In the programming mode the function to be set is active. This makes it easier to assign the outputs to the function keys. The dimming function can be altered via the speed knob. As soon as it is set as desired, it can be saved directly (online).

Setting the address via solder bridges

It is possible to set four different addresses via solder bridges, as an alternative to the setting of the address via online-programming. This possibility is of importance when programming via the central unit is not possible (e.g. Märklin* DELTA central unit).

Restrictions in Motorola I format

In Motorola I Format the following settings can be made:

- Address, starting and maximum velocity
- assignment of the function outputs to „function“

A reset and reading the address is not possible. It is not possible to program the second velocity characteristic or the acceleration and brake delay. The functions F1 to F4 cannot be switched.

Technical specifications

| | |
|--|----------------------------|
| Data format | Motorola II |
| Supply voltage | 12-24 Volt digital voltage |
| Current consumption (without connected loads) | approx. 10 mA |
| Max. current for motor | 1.000 mA |
| Max. current per function output | 500 mA |
| Max. total current | 1.500 mA |
| Protected to | IP 00 |
| Ambient temperature in use | 0 - + 60° C |
| Ambient temperature in storage | -10 - + 80° C |
| Comparative humidity allowed | max. 85 % |
| Dimensions | approx. 16,8 x 24 x 4,5 mm |
| Weight | approx. 2 g |

Checking the package contents

Check the contents of the package for completeness immediately after unpacking:

- one decoder, with or without soldered connecting wires, depending on the version,
- one manual.

N.B. For technical reasons it is possible that the PCB is not completely inserted. This is not a fault.

Required tools and materials

Make sure you have the following tools, equipment and materials ready for use:

- an electronic soldering iron (max. 30 Watt) with a fine tip,
- a soldering iron stand,
- a tip-cleaning sponge,
- a heat-resistant mat,
- a small side cutter and wire stripper,
- a pair of tweezers,
- tin solder (0,5 mm. diameter),
- wire (diameter: $\geq 0,05 \text{ mm}^2$ for all connections).

Safe and correct soldering

Caution:

Incorrect soldering can cause dangers through fires and heat. Avoid these dangers by reading and following the directions given in the chapter **Safety instructions**. If you have had training in soldering you can skip this chapter.

- Use a small soldering iron with max. 30 Watt. Keep the soldering tip clean so the heat of the soldering iron is applied to the solder point effectively.
- Only use tin solder SN 60 Pb (i.e. 60 % tin, 40 % lead) with rosin-based flux.
- When soldering electronic circuits never use soldering-water or soldering grease. They contain acids that can corrode components and copper tracks.
- Solder quickly: holding the iron on the joints longer than necessary can destroy components and can damage copper tracks or soldering eyes.
- Apply the soldering tip to the soldering spot in such a way that the wire and the soldering eye are heated at the same time.

Simultaneously add solder (not too much). As soon as the solder becomes liquid take it away. Hold the soldering tip at the spot for a few seconds so that the solder flows into the joint, then remove the soldering iron.

- The joint should be held still for about 5 seconds after soldering. A glossy and perfect soldering spot should remain.
- To make a good soldering joint you should use a clean and unoxidised soldering tip. Clean the soldering tip with a damp piece of cloth, a damp sponge or a piece of silicon cloth.
- After soldering check (preferably with a magnifying glass) tracks for accidental solder bridges and short circuits. This would cause faulty operation or, in the worst case, permanent damage. You can remove excess solder by putting a clean soldering tip on the spot. The solder will become liquid again and flow from the soldering spot to the soldering tip.

Mounting the locomotive decoder

Open the locomotive housing. Locate the position for the decoder. Disconnect the motor from the rail current collector respectively the change-over switch from the motor and rail current collector if you have a locomotive with (electronic) change-over switch. The change-over switch is no longer necessary, you can remove it.



Caution:

The interference suppression devices mounted to the motor or the connecting wire must not be removed! Motor and interference suppression devices are one unit. If even one part is removed, it can cause extreme interference!

Connecting the LD-G-1

Follow the connections diagrams (fig. 1a and 2a)! Solder the connection to the slider at point X3, and the connection to the housing to point X2. These two connections can be exchanged without effecting functionality. Solder the connections to the motor at the points X11 and X12.

Connecting the LD-W-1

Follow the connections diagrams (fig. 1a and 2b)! Solder the connection to the slider at point X3 and the connection to the housing to point X2. These two connections can be exchanged without effecting functionality. Solder the connections to the motor at the points X11, X12 and X13.

Connecting the lighting and other accessories

Disconnect any existing diodes in the leads to the lamps.

Connections to the outputs X7 to X10

The accessories connected to the outputs X7 to X10 are switched via the function keys F1 to F4. You will find the assignment of the outputs to the functions keys in the connections diagram Fig. 1.

Connections to the outputs X4 to X6

The accessories connected to the outputs X4 to X6 are assigned freely to the function keys "function" and F1 to F4 during the programming of the decoder. For that reason it is possible to connect the accessories to the function outputs any way.

If you want to use the decoder factory settings for the outputs X4 to X6, you have to connect the lighting and the accessories as follows:

Front lighting: X4

Back lighting: X5

Accessory independent of the direction to be switched via „function“: X6

Connections to the return conductor

Follow the connections diagrams (fig. 1a)! If the lamp or the accessory is already connected with one side to locomotive ground you should solder a diode between the decoder and the lamp or accessory. If not, connect the second side of the lamp or the accessory to the return conductor of the decoder (point X1).



Caution:

If you connect the loads to the return conductor for all functions (point

X1), the load must be insulated. The loads should not make contact with metal parts of the locomotive. Possible short circuit! The locomotive decoder will be damaged in operation.

**Caution:**

The return conductor for all functions (point X1) must under no circumstances be connected to locomotive ground. Possible short circuit! The locomotive decoder will be damaged in operation.

Tip: If the second side of the lamps is connected to locomotive ground the lamps often flicker in operation. You can avoid the flickering of the lamps if you connect the second side to the return conductor (point X1) instead of locomotive ground.

Advice: Before starting to program the locomotive decoder, you should connect a lamp to at least one of the function outputs X4 to X6, as the beginning of the programming mode as well as the entering of the set parameters is indicated by flashing the locomotive lighting.

Advice: Some accessories can not be checked for operation by switching on and off in short intervals (e.g. smoke generators). If you have connected accessories like these to the function outputs X4 to X6 of the decoder it is recommended to connect a lamp in parallel to the accessory during the programming of the decoder.

Connecting the LEDs

The function outputs of the locomotive decoder switch against decoder ground. For that reason you must connect the cathode (-) of the LED to the output of the relevant function.

**Caution:**

If you use light-emitting diodes (LEDs) you must always operate them via a series resistor.

LEDs are available in many different models. There are LEDs with 2-5 mA, but also LEDs with 15-30 mA power consumption. The series resistor limits the current flow of the LED and will need to be calculated for each model. Ask for the max current rating when buying your LEDs.

You can connect up to 5 LEDs in parallel to each output. In this case every LED must have a series resistor of its own. If you connect several LEDs to one output in series, only one series resistor is needed. The number of LEDs connected in series to one output depends on the digital voltage.

You can determine the number of the LEDs that can be connected in series to one output from the following formula:

$$\boxed{(\text{number of LEDs} + 2) \times 1,5 < \text{digital voltage}}$$

Fixing the locomotive decoder

After completing all connections fix the locomotive decoder with double-sided adhesive tape, for example.



Caution:

The locomotive decoder can get warm during operation. For that reason it should not be covered with shrinking hose or hot adhesive.

Setting the address via solder bridges

In state of delivery the decoder has the DELTA-address „78“. The addresses 24, 60 and 72 can be set via solder bridges (see fig. 1b).



Caution:

When one of the three above-mentioned addresses is set via solder bridges it is not possible to program another address via the central unit.

Programming the locomotive decoder

You can make the following adjustments from the central unit without intervention at the locomotive:

1. Locomotive address
2. Assignment of the function outputs X4 to X6 to the function keys
3. Dimming the function outputs
4. PWM-Period (= motor control frequency)
5. Definition of the forward direction
6. Velocity at speed level 1 for velocity characteristic 1

7. Maximum speed for velocity characteristic 1
8. Velocity at speed level 1 for velocity characteristic 2
9. Maximum speed for velocity characteristic 2
10. Automatic shuttle service: active or inactive
11. Acceleration delay for velocity characteristic 1
12. Brake delay for velocity characteristic 1

Accessing the programming mode

Put the vehicle on to a programming track or on the layout and reset the central unit (by simultaneously pushing the buttons "stop" and "go" for some time). Enter the address "78" at the central unit. Set the function key "function" of the central unit to "off".



Attention:

It does not matter if you have already saved another address. You always have to enter the address "78" to access the programming mode. If you put the vehicle for programming on the layout take off all other vehicles with decoders with online-programming. If not you programm these vehicles as well.

Push the "stop" button at the central unit. Next, operate the direction switch and hold it in that position while briefly pushing the "go" button. As soon as the lamps connected to the outputs X4 to X6 flash (after approx. 2 seconds) you are in the programming mode and can release the direction switch.

Notice: Some types of central units do not allow you to access to the programming mode when the Motorola II format is set (e.g. Intellibox** from Uhlenbrock). In order to start the programming mode these central units must be set to Motorola I format for the address "78". As soon as the decoder is in the programming mode, the central unit must be set back to Motorola II format.

Starting from this menu level you can:

Without any further inputs: Set the address and the functions.

After pushing the function key F1: Query the address.

After pushing the function key F2: Perform a decoder reset.

After pushing the function key F3: Set the driving characteristics.

You can finish the programming mode at any time by disconnecting the vehicle (pushing the button „stop“ or taking the vehicle from the track).

Setting the locomotive address and the functions

1. Setting the locomotive address

You are in the menu point „Setting the locomotive address“ when all lighting connected to the function outputs X4 to X6 flash regularly. Enter the desired address. You do not need to enter the old address. Confirm your setting by switching the function key „function“ on and off once. After the taking-over of the locomotive address the regular flashing of the connected lighting stops and the decoder proceeds immediately to the programming of the first function output.

2. Setting the function outputs

Now the function outputs X4, X5 and X6 are programmed one after the other. The function keys are assigned in succession, and the dimming function is set for each output.

Assigning the function keys: While the program continuously switches the output to be programmed on and off (and the lighting connected to the output flashes) switch on the functions key(s) F1 to F4 on your central unit with which you want to switch the output in later operation. You can assign several function keys to one output of the decoder. Please notice that in operation the second velocity characteristic is activated and the acceleration and brake delay is deactivated via F4.

If you want to switch the function output in operation via „function“ you have to make the following settings:

Speed level 1 : Output will be switched on during backwards motion.

Speed level 2 : Output will be switched on during forward motion.

Speed level 3 : Output will be switched on independent of the direction of motion.

Advice: On the Märklin* Central Unit 6021 the speed levels 1,2 and 3 correspond to the settings 20, 40 and 60.

Confirm your settings by switching the function key „function“ on and off once.

Setting the dimming function: The dimming function is set via the speed knob. Speed level 0 stands for minimal voltage (if lamps are connected minimal brightness) at the output to be set and speed level 14 (250 on Märklin* Control Unit 6021) maximal voltage. Confirm your setting by switching the function key „function“ on and off once.

Repeat the assignment of the function keys and the setting of the dimming function for the other two function outputs. You can skip the programming of an output that is not occupied by switching on and off the function key „function“ two times.

As soon as all functions are set the the lamps connected to the outputs X4 to X6 flash flash several times. You automatically proceed to the menu point „Setting the driving characteristics“. If you want to close the programming mode you just disconnect the locomotive.

Setting the driving characteristics

1. Setting the driving characteristics - step 1

You get to this menu point automatically from the menu point „Setting the address and the functions“ or by pushing the function key F3 when entering the top menu level.

Setting the driving characteristic: First select the velocity characteristic you want to set:

Characteristic 1: Function F4 off.

Characteristic 2: Function F4 on.

Definition of the direction of travel: Operate the speed knob and check the actual direction of travel. Check if the direction of travel of the locomotive corresponds to the direction of travel set at the central unit. If the actual and the set direction do not correspond operate the function key „F2“.

Choosing the PWM period: Next determine the PWM period (= motor control frequency).

PWM period = 125 Hz: function F1 off.

PWM period = 1800 Hz: function F1 on.

N.B. Some motors drive with a high PWM period more smoothly and consume less current (e.g. locomotives for large scales). On other motors a high PWM period has negative effects (e.g. high-performance engine). You should try which PWM period is the right one in the individual case.

Setting the starting velocity: Operate the speed knob. As soon as the locomotive moves with the desired starting velocity, you should switch the function key „function“ on and off once. The locomotive decoder confirms the taking-over of the starting velocity by flashing the lighting of the locomotive once. Set the speed knob to "0".

Setting the maximum velocity: Operate the speed knob. As soon as the locomotive moves with the desired maximum velocity, you should switch the function key „function“ on and off once. The locomotive decoder confirms the taking-over of the maximum velocity by flashing the lighting of the locomotive twice.

The program automatically goes back to the start of this programming step. You may change your settings or make the settings for the second velocity characteristic. In order to get to the next programming step you have to operate the direction switch.

2. Setting the driving characteristics - step 2

During this programming step the locomotive continuously accelerates and brakes.

Setting the automatic shuttle service (for both velocity characteristics): Set if the automatic shuttle service is to be active or not in later operation.

Shuttle service in later operation active: Function F3 on.

Shuttle service in later operation active: Function F3 off.

When the automatic shuttle service is activated the locomotive changes the direction of travel after the next braking operation and keeps up the shuttle service during the whole programming step.

Setting the brake delay service (for velocity characteristic 1): Switch off the auxiliary function F1. The locomotive accelerates with the acceleration delay set in state of delivery or in a former programming.

Then it brakes with the brake delay set at the speed knob. You may modify the brake delay by operating the speed knob. Speed level 0 corresponds to no brake delay, speed level 14 (250 on the Märklin* Control unit) to maximum brake delay. As soon as the brake delay is set as desired you have to confirm your setting by switching the function key „function“ on and off once.

Setting the acceleration delay: Now switch on the auxiliary function F1. The locomotive accelerates with the acceleration delay set at the speed knob and then brakes with the brake delay set before. Continue as described in section: „Setting the brake delay“. As soon as the acceleration delay is set as desired you have to confirm your setting by switching the function key „function“ on and off once.

During this programming step you may switch the automatic shuttle service on or off as required by operating F3 and also change between setting the brake or the acceleration delay by operating F1.

When all settings are made, you close the programming mode by disconnecting the decoder (pushing the button „stop“ or taking the locomotive from the track).

Querying the decoder address

You get to this programming step only by operating the function key F1 on the top menu level after having started the programming mode. The lighting of the locomotive now starts to flash. Two flashing signals interrupted by a short stop transmit the coded address. After a longer pause the two flashing signals are repeated. You'll find the meaning of the flashing signals in the appendix. You get back to the standard operation by disconnecting the locomotive.

Performing a decoder reset

You get to this programming step only by operating the function key F2 on the top menu level after having started the programming mode. By operating the function key F2 you restore the factory settings (and all other settings are deleted). Then the decoder continues automatically in standard operation.

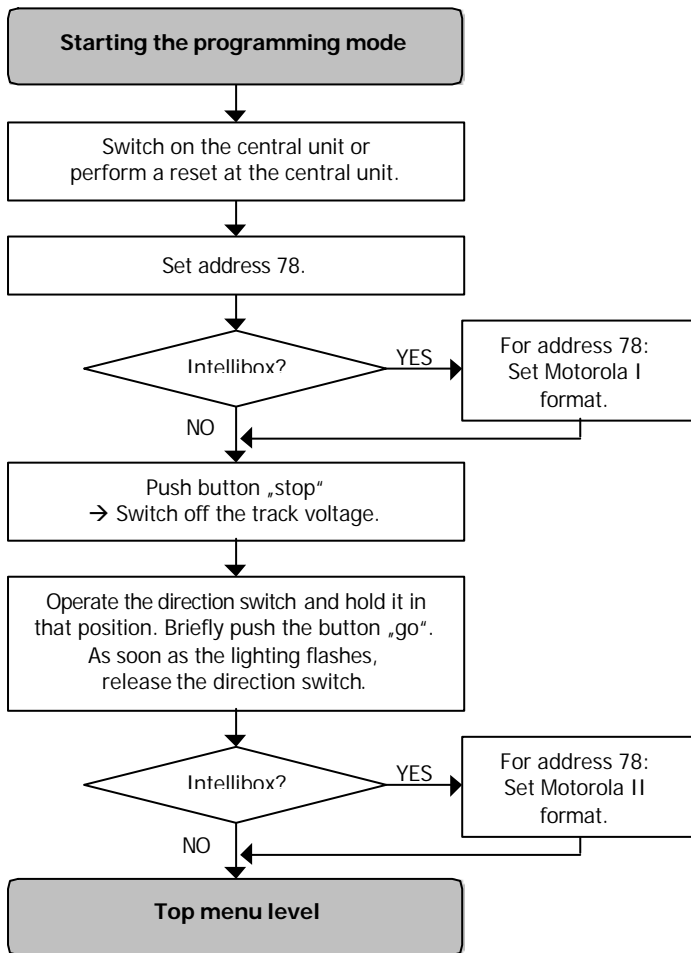

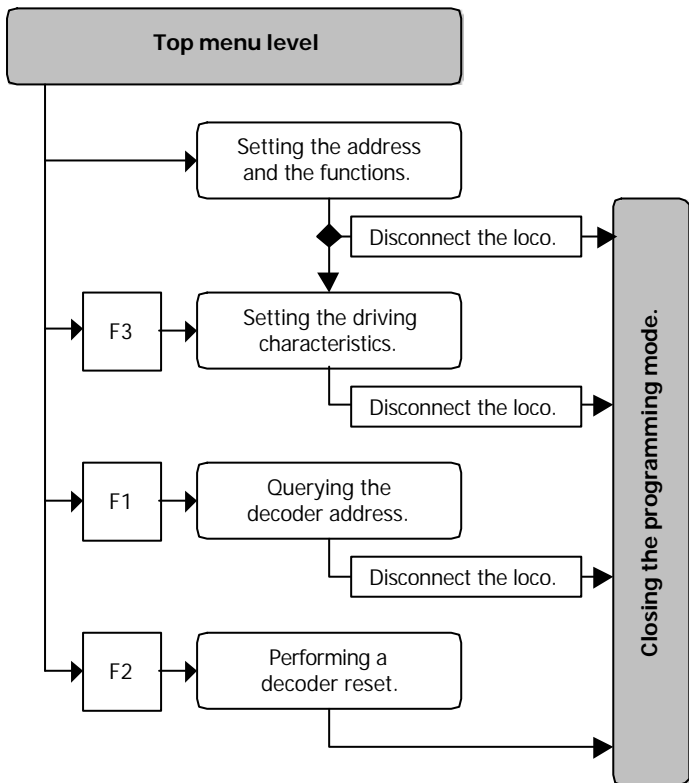

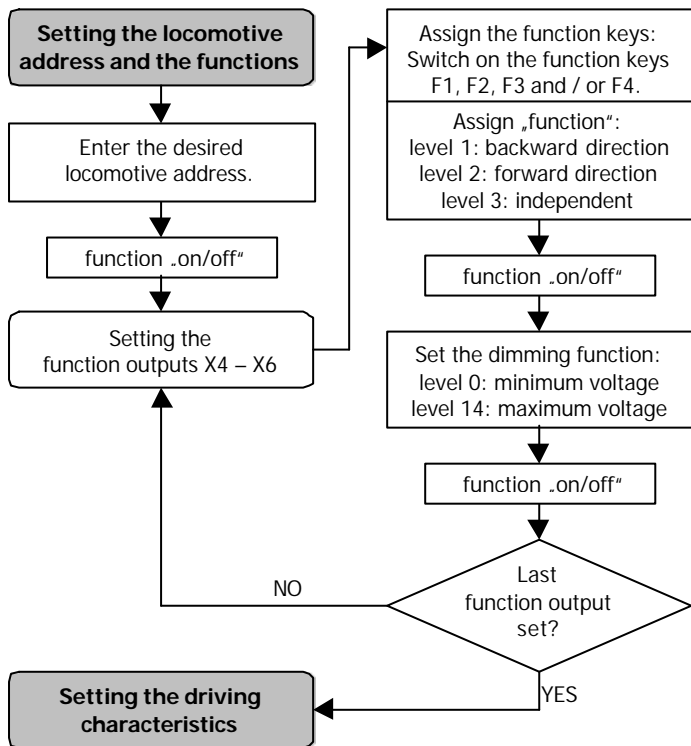

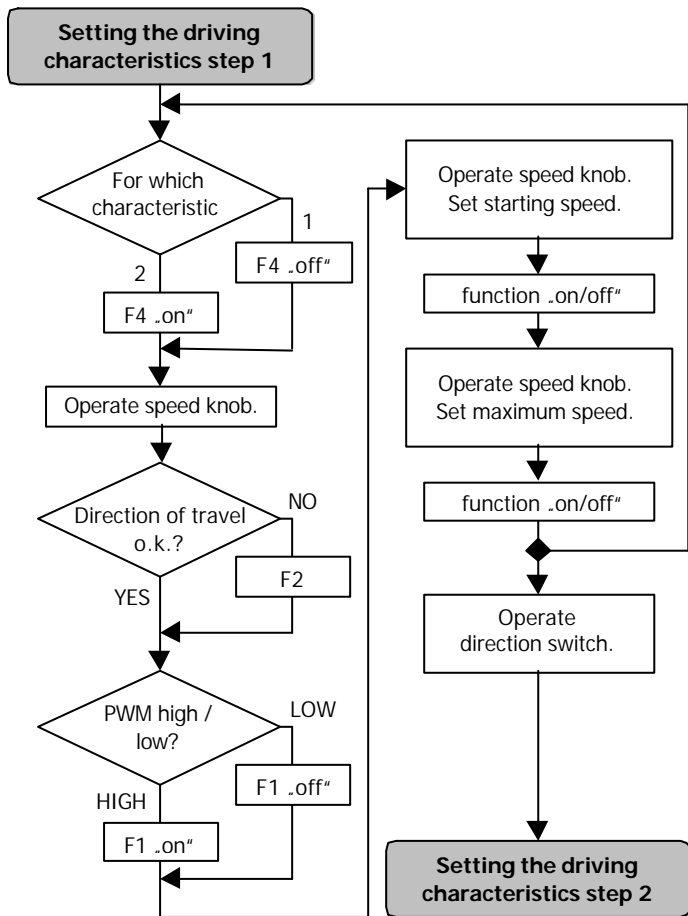

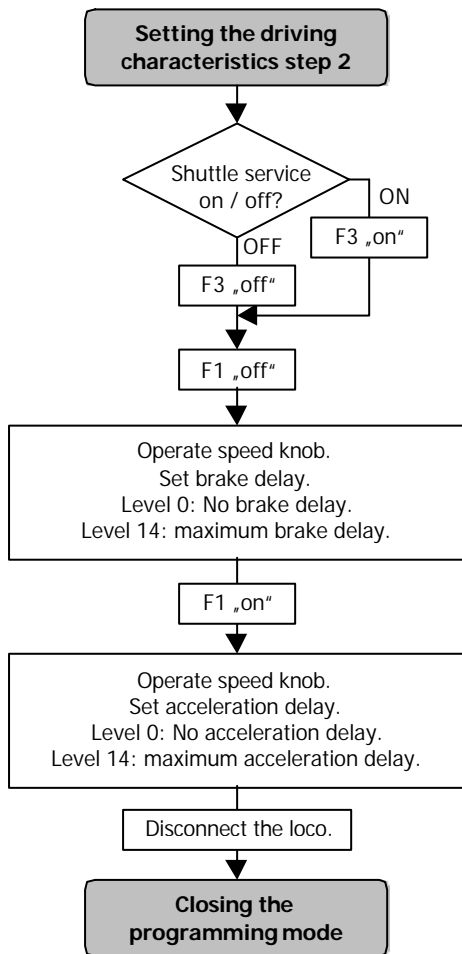

Operation

Acceleration and brake delay / Second velocity characteristic

In Motorola II format you can switch the acceleration and brake delay on or off and you can switch between the two velocity characteristics via F4.

F4 off: Delay active and characteristic 1 set.

The setting is immediately active.

In Motorola I format you cannot switch the acceleration and brake delay on or off and you cannot switch to the second velocity characteristic. The acceleration and brake delay is always active.

An emergency stop can be made via the central unit by reversing the direction.

Improvement of the driving characteristics

Locomotives with especially high current consumption or track sections with bad contacts (e.g. some types of points) may give an unsatisfactory performance. You can improve the locomotive performance by soldering a capacitor 100 μ F / 35 V between X16 and X17 (see fig. 2a resp. 2b).

Analogue mode

In analogue mode the decoder can be run like a change-over switch. This means the decoder reacts with a change of direction on the shift impulse of the speed control knob, as usual. In analogue mode the lighting and the accessory connected to X6 are always switched on. The lighting is switched depending on the direction of travel.

You access the analogue mode by pressing the direction switch of the analogue driving transformer until the light of the locomotive starts flashing. To get back into the digital mode, press the direction switch of the analogue driving transformer again until the light of the locomotive starts to flash.

FAQ

- Parts are getting too hot and/or start to smoke.



Disconnect the system from the mains immediately!

Possible cause: one or more connections are soldered incorrectly.

→ Check the connections.

Possible cause: The connection of the motor is connected to locomotive ground. → Disconnect the connection from locomotive ground.

- A lamp flickers (this is not a defect).

Possible cause: The lamp is connected with one side to locomotive ground. → If you do not want the lamp to flicker, disconnect it from locomotive ground, insulate it and connect it to the return conductor (point X1).

- The locomotive runs too slowly or too fast.

Possible cause: Different locomotives react in different ways to identical programmings. → Adapt the programming to the individual characteristics of the locomotive.

- The locomotive does not react to F4.

Possible cause: Instead of Motorola II format, Motorola I format is set at the central unit. → Set Motorola II format.

If you cannot find the problem, please return the decoder for repair (address on the cover page).

Manufacturer's note

According to DIN VDE 0869, the person who brings the circuit into operation by extension resp. mounting into a housing is the manufacturer of the product. If he sells the product to another person he is responsible for passing on all the relevant papers and to give his name and address.

Certification

This product conforms with the EC- directive 89/336/EWG on electromagnetic radiation and is therefore CE certified.

Conditions of warranty

This product is guaranteed for two years. The warranty includes the correction of faults which can be proved to be due to material failure or factory flaw. We guarantee the adherence to the technical specifications of the circuit when assembled and connected according to the manual.

Other claims are excluded. By law, we are not responsible for damages or secondary damages in connection with this product. We retain the right to repair, make improvements, supply spare parts or return the purchase price.

The following invalidate the warranty:

- using an unsuitable soldering iron, solder containing liquid acids or similar,
- if damage is caused by not following the instructions in this manual or the connection diagram(s),
- if the module has been altered and repair attempts have failed,
- if arbitrary changes in the circuit are made,
- additional components are added which are not described in the manual,
- if the copper tracks or soldering eyes are damaged,
- if damage occurs due to an overload of the module,
- if connected to a incorrect voltage or current,
- if damaged by other persons,
- if damaged by faulty operation or if damaged by careless use or abuse,
- if damaged by touching components before electrostatic discharging of the hands.

Tabelle: Rückmeldung der Decoderadresse

Appendix: Check back of the address

Tableau : Indiquation de l'adresse du décodeur

Tabel: Terugmelding van het decoderadres

| Flash 1 * | Flash 2 * | Ad. ** |
|-----------|-----------|--------|
| 1 | 1 | 80 |
| 1 | 2 | 2 |
| 1 | 3 | 81 |
| 1 | 4 | 1 |
| 1 | 5 | 6 |
| 1 | 6 | 8 |
| 1 | 7 | 82 |
| 1 | 8 | 7 |
| 1 | 9 | 145 |
| 1 | 10 | 177 |
| 1 | 11 | 191 |
| 1 | 12 | 161 |
| 1 | 13 | 3 |
| 1 | 14 | 5 |
| 1 | 15 | 84 |
| 1 | 16 | 4 |
| 2 | 1 | 18 |
| 2 | 2 | 20 |
| 2 | 3 | 85 |
| 2 | 4 | 19 |
| 2 | 5 | 24 |
| 2 | 6 | 26 |
| 2 | 7 | 86 |
| 2 | 8 | 25 |
| 2 | 9 | 146 |
| 2 | 10 | 178 |
| 2 | 11 | 87 |
| 2 | 12 | 162 |
| 2 | 13 | 21 |
| 2 | 14 | 23 |
| 2 | 15 | 88 |
| 2 | 16 | 22 |

| Flash 1 * | Flash 2 * | Ad. ** |
|-----------|-----------|--------|
| 3 | 1 | 193 |
| 3 | 2 | 201 |
| 3 | 3 | 89 |
| 3 | 4 | 197 |
| 3 | 5 | 217 |
| 3 | 6 | 225 |
| 3 | 7 | 90 |
| 3 | 8 | 221 |
| 3 | 9 | 147 |
| 3 | 10 | 179 |
| 3 | 11 | 91 |
| 3 | 12 | 163 |
| 3 | 13 | 205 |
| 3 | 14 | 213 |
| 3 | 15 | 92 |
| 3 | 16 | 209 |
| 4 | 1 | 9 |
| 4 | 2 | 11 |
| 4 | 3 | 93 |
| 4 | 4 | 10 |
| 4 | 5 | 15 |
| 4 | 6 | 17 |
| 4 | 7 | 94 |
| 4 | 8 | 16 |
| 4 | 9 | 148 |
| 4 | 10 | 180 |
| 4 | 11 | 95 |
| 4 | 12 | 164 |
| 4 | 13 | 12 |
| 4 | 14 | 14 |
| 4 | 15 | 96 |
| 4 | 16 | 13 |

| Flash 1 * | Flash 2 * | Ad. ** |
|-----------|-----------|--------|
| 5 | 1 | 54 |
| 5 | 2 | 56 |
| 5 | 3 | 97 |
| 5 | 4 | 55 |
| 5 | 5 | 60 |
| 5 | 6 | 62 |
| 5 | 7 | 98 |
| 5 | 8 | 61 |
| 5 | 9 | 149 |
| 5 | 10 | 181 |
| 5 | 11 | 99 |
| 5 | 12 | 165 |
| 5 | 13 | 57 |
| 5 | 14 | 59 |
| 5 | 15 | 100 |
| 5 | 16 | 58 |
| 6 | 1 | 72 |
| 6 | 2 | 74 |
| 6 | 3 | 101 |
| 6 | 4 | 73 |
| 6 | 5 | 78 |
| 6 | 6 | --- |
| 6 | 7 | 102 |
| 6 | 8 | 79 |
| 6 | 9 | 150 |
| 6 | 10 | 182 |
| 6 | 11 | 103 |
| 6 | 12 | 166 |
| 6 | 13 | 75 |
| 6 | 14 | 77 |
| 6 | 15 | 104 |
| 6 | 16 | 76 |
| 7 | 1 | 194 |
| 7 | 2 | 202 |
| 7 | 3 | 105 |
| 7 | 4 | 198 |

| Flash 1 * | Flash 2 * | Ad. ** |
|-----------|-----------|--------|
| 7 | 5 | 218 |
| 7 | 6 | 226 |
| 7 | 7 | 106 |
| 7 | 8 | 222 |
| 7 | 9 | 151 |
| 7 | 10 | 183 |
| 7 | 11 | 107 |
| 7 | 12 | 167 |
| 7 | 13 | 206 |
| 7 | 14 | 214 |
| 7 | 15 | 108 |
| 7 | 16 | 210 |
| 8 | 1 | 63 |
| 8 | 2 | 65 |
| 8 | 3 | 109 |
| 8 | 4 | 64 |
| 8 | 5 | 69 |
| 8 | 6 | 71 |
| 8 | 7 | 110 |
| 8 | 8 | 70 |
| 8 | 9 | 152 |
| 8 | 10 | 184 |
| 8 | 11 | 111 |
| 8 | 12 | 168 |
| 8 | 13 | 66 |
| 8 | 14 | 68 |
| 8 | 15 | 112 |
| 8 | 16 | 67 |
| 9 | 1 | 229 |
| 9 | 2 | 231 |
| 9 | 3 | 113 |
| 9 | 4 | 230 |
| 9 | 5 | 235 |
| 9 | 6 | 237 |
| 9 | 7 | 114 |
| 9 | 8 | 236 |

| Flash 1 * | Flash 2 * | Ad. ** |
|-----------|-----------|--------|
| 9 | 9 | 153 |
| 9 | 10 | 185 |
| 9 | 11 | 115 |
| 9 | 12 | 169 |
| 9 | 13 | 232 |
| 9 | 14 | 234 |
| 9 | 15 | 116 |
| 9 | 16 | 233 |
| 10 | 1 | 247 |
| 10 | 2 | 249 |
| 10 | 3 | 117 |
| 10 | 4 | 248 |
| 10 | 5 | 253 |
| 10 | 6 | 255 |
| 10 | 7 | 118 |
| 10 | 8 | 254 |
| 10 | 9 | 154 |
| 10 | 10 | 186 |
| 10 | 11 | 119 |
| 10 | 12 | 170 |
| 10 | 13 | 250 |
| 10 | 14 | 252 |
| 10 | 15 | 120 |
| 10 | 16 | 251 |
| 11 | 1 | 195 |
| 11 | 2 | 203 |
| 11 | 3 | 121 |
| 11 | 4 | 199 |
| 11 | 5 | 219 |
| 11 | 6 | 227 |
| 11 | 7 | 122 |
| 11 | 8 | 223 |
| 11 | 9 | 155 |
| 11 | 10 | 187 |
| 11 | 11 | 192 |
| 11 | 12 | 171 |

| Flash 1 * | Flash 2 * | Ad. ** |
|-----------|-----------|--------|
| 11 | 13 | 207 |
| 11 | 14 | 215 |
| 11 | 15 | 124 |
| 11 | 16 | 211 |
| 12 | 1 | 238 |
| 12 | 2 | 240 |
| 12 | 3 | 125 |
| 12 | 4 | 239 |
| 12 | 5 | 244 |
| 12 | 6 | 246 |
| 12 | 7 | 126 |
| 12 | 8 | 245 |
| 12 | 9 | 156 |
| 12 | 10 | 188 |
| 12 | 11 | 127 |
| 12 | 12 | 172 |
| 12 | 13 | 241 |
| 12 | 14 | 243 |
| 12 | 15 | 128 |
| 12 | 16 | 242 |
| 13 | 1 | 27 |
| 13 | 2 | 29 |
| 13 | 3 | 129 |
| 13 | 4 | 28 |
| 13 | 5 | 33 |
| 13 | 6 | 35 |
| 13 | 7 | 130 |
| 13 | 8 | 34 |
| 13 | 9 | 157 |
| 13 | 10 | 189 |
| 13 | 11 | 131 |
| 13 | 12 | 173 |
| 13 | 13 | 30 |
| 13 | 14 | 32 |
| 13 | 15 | 132 |
| 13 | 16 | 31 |

| Flash 1 * | Flash 2 * | Ad. ** |
|-----------|-----------|--------|
| 14 | 1 | 45 |
| 14 | 2 | 47 |
| 14 | 3 | 133 |
| 14 | 4 | 46 |
| 14 | 5 | 51 |
| 14 | 6 | 53 |
| 14 | 7 | 134 |
| 14 | 8 | 52 |
| 14 | 9 | 158 |
| 14 | 10 | 190 |
| 14 | 11 | 135 |
| 14 | 12 | 174 |
| 14 | 13 | 48 |
| 14 | 14 | 50 |
| 14 | 15 | 136 |
| 14 | 16 | 49 |
| 15 | 1 | 196 |
| 15 | 2 | 204 |
| 15 | 3 | 137 |
| 15 | 4 | 200 |
| 15 | 5 | 220 |
| 15 | 6 | 228 |
| 15 | 7 | 138 |
| 15 | 8 | 224 |

| Flash 1 * | Flash 2 * | Ad. ** |
|-----------|-----------|--------|
| 15 | 9 | 159 |
| 15 | 10 | 83 |
| 15 | 11 | 139 |
| 15 | 12 | 175 |
| 15 | 13 | 208 |
| 15 | 14 | 216 |
| 15 | 15 | 140 |
| 15 | 16 | 212 |
| 16 | 1 | 36 |
| 16 | 2 | 38 |
| 16 | 3 | 141 |
| 16 | 4 | 37 |
| 16 | 5 | 42 |
| 16 | 6 | 44 |
| 16 | 7 | 142 |
| 16 | 8 | 43 |
| 16 | 9 | 160 |
| 16 | 10 | 123 |
| 16 | 11 | 143 |
| 16 | 12 | 176 |
| 16 | 13 | 39 |
| 16 | 14 | 41 |
| 16 | 15 | 144 |
| 16 | 16 | 40 |

- * Anzahl der Blinkzeichen / Number of flashing signals
Flash 1: vor der kurzen Pause / before the short stop
Flash 2: nach der kurzen Pause / after the short stop
- * Nombre des clignotements / Aantal knipperingen
Flash 1: avant la courte pause / voor de korte pauze
Flash 2: après la courte pause / na de korte pauze
- ** Adresse / address / adresse / adres

Fig. 1: Anschlußpläne - Connection Diagrams - Schémas de connexion - Aansluitplannen

Fig. 1a: Vorderseite / Front / Face avant / Frontzijde

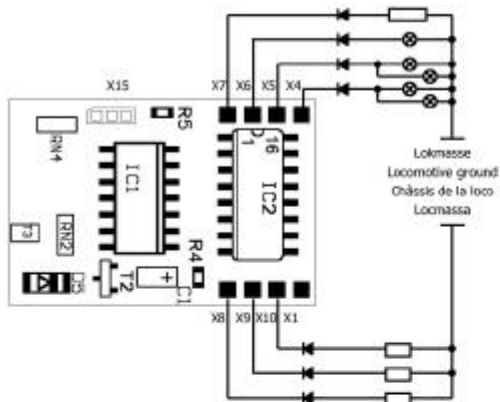

Verbindung des 2. Anschlusses mit Lokmasse
 Connection of the 2nd side to locomotive ground
 Raccordement des fonctions via le châssis de la loco
 Verbinding van de 2e aansluiting met de loomassa

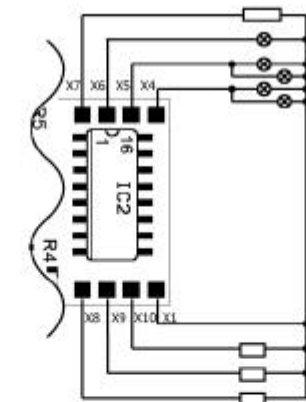

oder: Anschluß bei Verwendung des Rückleiters X1
 or: Connection when using the return conductor X1
 ou: Raccordement des fonctions vi la borne commune X1
 of: Aansluiten bij gebruik van de retourleiding X1

Fig. 1b: Adresseinstellung über Löt pads an X15 / Setting the address via solder bridges
 Sélection de l'adresse par pontage à X15 / Adresinstelling middels soldeerbruggen aan X15

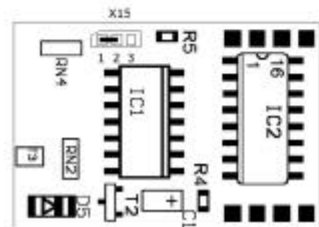

| Adr. | 78 | 72 | 60 | 24 |
|------|----|----|----|----|
| 1-2 | - | x | - | x |
| 2-3 | - | - | x | x |

Beispiel: Einstellung der Adresse "72"
 Exemple: Adjusting the address "72"
 Exemple: Réglage de l'adresse "72"
 Voorbeeld: Instellen van adres "72"

| | |
|-----|---|
| X1 | Rückleiter für alle Funktionen Return conductor for all functions Retour pour toutes les fonctions Retourdraad voor alle functies |
| X4 | Beleuchtung Vorwärtsfahrt (graues Kabel) Lampe vorne: weiß - Lampe hinten: rot Lighting forward direction (grey cable) Lamp front: white - Lamp back: red Feux marche avant (fil gris) Lampe avant: blanche - Lampe arrière: rouge Verlichting vooruitrijden (grijs draad) Lampe voor: wit - Lampe achter: rood |
| X5 | Beleuchtung Rückwärtsfahrt (gelbes Kabel) Lampe vorne: rot - Lampe hinten: weiß Lighting reverse direction (yellow cable) Lamp front: red - Lamp back: white Feux marche arrière (fil jaune) Lampe avant: rouge - Lampe arrière: blanche Verlichting achteruitrijden (gele draad) Lampe voor: rood - Lampe achter: wit |
| X6 | "function" an / aus "function" on / off "function" marche / arrêt "function" aan / uit |
| X7 | F1 |
| X8 | F2 |
| X9 | F3 |
| X10 | F4 |
| X15 | Adresseinstellung über Löt pads Setting the address via solder bridges Sélection de l'adresse par pontage Adresinstelling middels soldeerbruggen |
| | Diode 1N4007 oder ähnlich / or similar / ou similaire / of gelijkwaardig |
| | Befehliger Verbraucher (z.B. Rauchgenerator, Führerstandsbeleuchtung, Geräuschmodul) Optional accessories (e.g. smoke generator, cab lighting, noise module) Consommateurs divers (par ex. fumigène, éclairage cabine, module sonore) Willekeurige verbruiker (b.v. rookgenerator, machinistenhuisverlichting, geluudmodule) |

Fig. 2: Anschlußpläne - Connection Diagrams - Schémas de connexion - Aansluitplannen

Fig. 2a:

Rückseite LD-G-1
Rear LD-G-1
Face arrière LD-G-1
Achterzijde LD-G-1

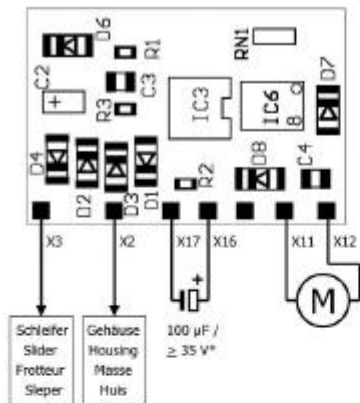
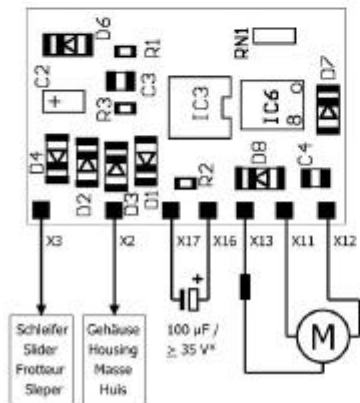

Fig. 2b:

Rückseite LD-W-1
Rear LD-W-1
Face arrière LD-W-1
Achterzijde LD-W-1



| | |
|-----------|--|
| X2 | Gehäuse / Housing / Masse / Huis |
| X3 | Schleifer / Slider / Frotteur / Sleper |
| X11 | Feldwicklung "vor" des Motors (grünes Kabel) "Forwards" field winding of the motor (green cable) Bobinage d'induit "marche avant" du moteur (fil vert) Veldwikkling "heen" van de motor (groene draad) |
| X12 | Feldwicklung "zurück" des Motors (blaues Kabel) "Backwards" field winding of the motor (blue cable) Bobinage d'induit "marche arrière" du moteur (fil bleue) Veldwikkling "terug" van de motor (blauwe draad) |
| X13 | LD-W-1: Rückleiter des Motors (schwarzes Kabel) Return conductor of the motor (black cable) Retour du moteur (fil noir) Retourleiding van de motor (zwarte draad) |
| X16 / X17 | * Elko, falls erforderlich. * Capacitor, if necessary. * Condensateur, si nécessaire. * Condensator, indien noodzakelijk. |
| | * Entstörmittel. Nicht ausbauen! * Interference suppression devices. Do not remove! * Dispositifs antiparasites. Ne pas enlever! * Ontstoringsonderdelen. Niet verwijderen! |

Fig. 3: Schaltplan - Circuit Diagram - Schéma de principe - Schakelplan

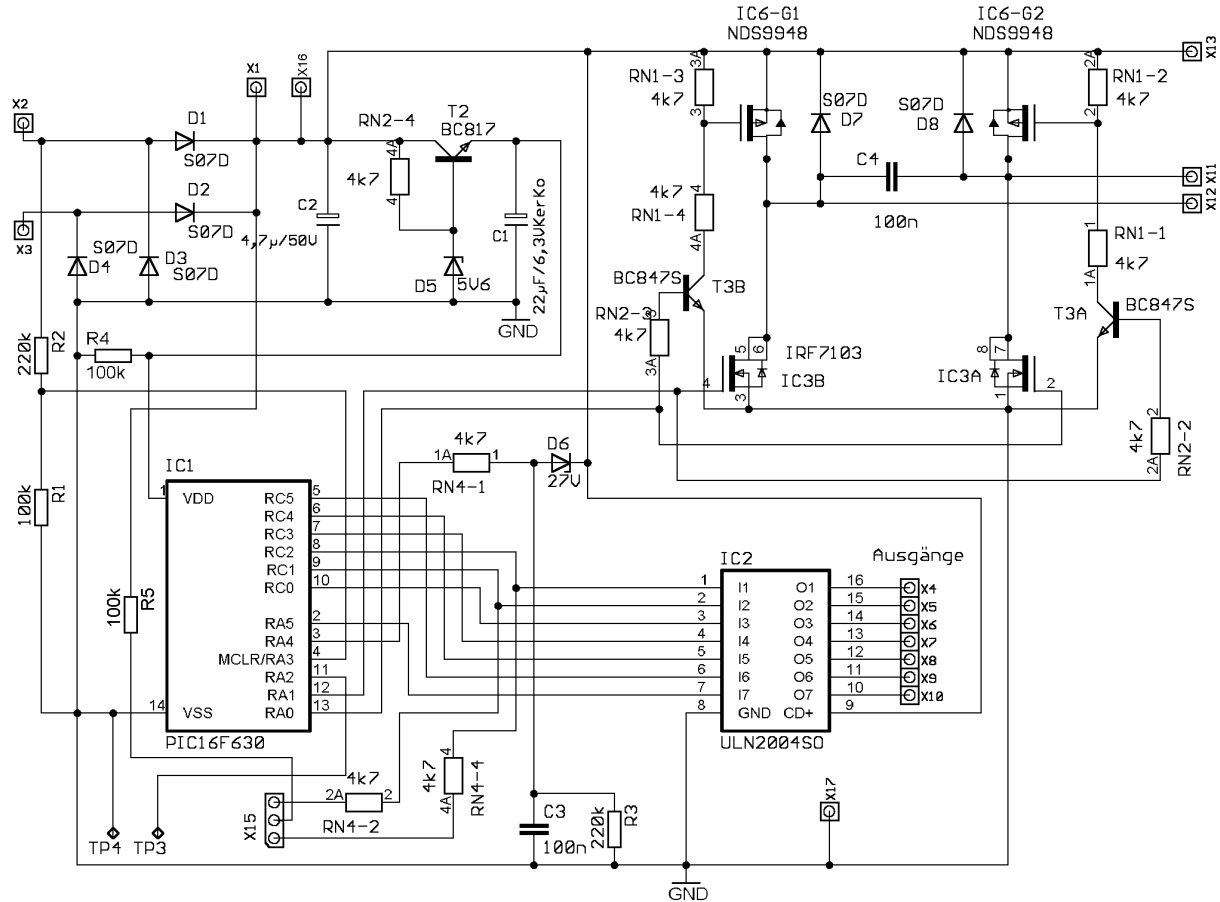

Aktuelle Informationen und Tipps:

Information and tips:

Informations et conseils:

Actuele informatie en tips:

<http://www.tams-online.de>

Garantie und Service:

Warranty and service:

Garantie et service:

Garantie en service:

Tams Elektronik GmbH

Rupsteinstraße 10

D-30625 Hannover

fon: +49 (0)511 / 55 60 60

fax: +49 (0)511 / 55 61 61

e-mail: modellbahn@tams-online.de