

LD-W-7

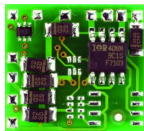

Lokdecoder für Wechselstrommotoren

DCC-Format

Locomotive Decoder for AC engines

DCC-Format

Décodeur pour locomotive avec moteur alternatif

Format-DCC

Locdecoder voor wisselstroommotoren

DCC-format

Art.-Nr. 22-01-055

LD-G-7

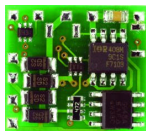

Lokdecoder für Gleichstrommotoren

DCC-Format

Locomotive Decoder for DC engines

DCC-Format

Décodeur pour locomotive avec moteur continu

Format-DCC

Locdecoder voor gelijkstroommotoren

DCC-format

Art.-Nr. 22-01-056

Art.-Nr. 22-01-057

Anleitung

Manual

Mode d'emploi

Handleiding



© 12/2004 Tams Elektronik GmbH

Alle Rechte, insbesondere das Recht der Vervielfältigung und Verbreitung sowie der Übersetzung vorbehalten. Vervielfältigungen und Reproduktionen in jeglicher Form bedürfen der schriftlichen Genehmigung durch die Tams Elektronik GmbH.

Technische Änderungen vorbehalten.

© 12/2004 Tams Elektronik GmbH

All rights reserved. No part of this publication may be reproduced or transmitted in any form or by any means, electronic or mechanical, including photocopying, without prior permission in writing from Tams Elektronik GmbH.

Subject to technical modification.

© 12/2004 Tams Elektronik GmbH

Tout droits réservés, en particulier les droits de reproduction et de diffusion ainsi que le traduction. Toute duplication ou reproduction sous quelque forme que ce soit nécessite l'accord écrit de la société Tams Elektronik GmbH.

Sous réserve de modifications techniques.

© 12/2004 Tams Elektronik GmbH

Alle rechten voorbehouden. Niets uit deze publicatie mag worden vermenigvuldigd opgeslagen of openbaar gemaakt, zonder voorafgaande schriftelijke toestemming van Tams Elektronik GmbH.

Technische wijzigingen voorbehouden.



■ **Deutsch** 3

■ **English** 22

■ **Français** 40

■ **Nederlands** 58



Table of contents

How to use this manual	23
Intended use	23
Safety instructions	24
EMC declaration	26
Information: Speed mode	26
Information: Configuration variables (CVs)	26
Operation overview	27
Technical specifications	29
Checking the package contents	30
Required tools and materials	30
Safe and correct soldering	30
Mounting the locomotive decoder	32
Programming the locomotive decoder	35
Improvement of the driving characteristics	37
FAQ	37
Manufacturer's note	38
Certification	38
Conditional warranty	38
Connections (Fig. 1 and 2)	I
Circuit Diagram (Fig. 3)	II
(Pages I to II in the centre of this handbook are removeable.)	

How to use this manual

If you have no specialist technical training, this manual gives step-by-step instructions for safe and correct fitting of the module, and operation. Before you start, we advise you to read the whole manual, particularly the chapter on safety instructions and the FAQ chapter. You will then know where to take care and how to prevent mistakes which take a lot of effort to correct.

Keep this manual safely so that you can solve problems in the future. If you pass the module on to another person, please pass on the manual with it.

Intended use

Caution:

Integrated circuits are very sensitive to static electricity. Do not touch components without first discharging yourself. Touching a radiator or other grounded metal part will discharge you.

The module can be used according to the specifications of this manual in a model railway. It is designed for the mounting in a model railway locomotive with d.c. motor (LD-G-7) or a.c. motor (LD-W-7). It evaluates the DCC format data sent by the digital control unit to its address. The decoder controls the vehicle performance (velocity, direction of travel, acceleration) and switches two outputs.

The module should not be assembled or operated by children under the age of 14.

Reading, understanding and following the instructions in this manual are mandatory for the user.

Any other use is inappropriate and invalidates any guarantees.

Safety instructions

Mechanical hazards

Cut wires can have sharp ends and can cause serious injuries. Watch out for sharp edges when you pick up the PCB.

Visibly damaged parts can cause unpredictable danger. Do not use damaged parts: recycle and replace them with new ones.

Electrical hazards

- Touching powered, live components,
- touching conducting components which are live due to malfunction,
- short circuits,
- connecting the circuit to another voltage than specified,
- impermissibly high humidity,
- condensation build up

can cause serious injury due to electrical shock. Take the following precautions to prevent this danger:

- Never perform wiring on a powered module.
- Mounting the module should only be done in closed, clean, dry rooms. Beware of humidity.
- Only use low power for this module as described in this manual and only use certified transformers.
- Connect transformers and soldering irons only in approved mains sockets installed by an authorised electrician.
- Observe cable diameter requirements.
- After condensation build up, allow a minimum of 2 hours for dispersion.
- Use only original spare parts if you have to repair the module.

Fire risk

Touching flammable material with a hot soldering iron can cause fire, which can result in injury or death through burns or suffocation. Connect your soldering iron or soldering station only when actually needed. Always keep the soldering iron away from inflammable materials. Use a suitable soldering iron stand. Never leave a hot soldering iron or station unattended.

Thermal danger

A hot soldering iron or liquid solder accidentally touching your skin can cause skin burns. As a precaution:

- use a heat-resistant mat during soldering,
- always put the hot soldering iron in the soldering iron stand,
- point the soldering iron tip carefully when soldering, and
- remove liquid solder with a thick wet rag or wet sponge from the soldering tip.

Dangerous environments

A working area that is too small or cramped is unsuitable and can cause accidents, fires and injury. Prevent this by working in a clean, dry room with enough freedom of movement.

Other dangers

Children can cause any of the accidents mentioned above because they are inattentive and not responsible enough. Children under the age of 14 should not be allowed to work with this module.

Little children can swallow small components with sharp edges, with fatal results! Do not allow components to reach small children.

In schools, training centres, clubs and workshops, assembly, mounting and operation must be supervised by qualified personnel.

In industrial institutions, health and safety regulations applying to electronic work must be adhered to.

EMC declaration

This product is developed in accordance with the European standards EN 55014 and EN 50082-1, tested corresponding to the EC - directive 89/336/EEG (EMVG of 09/11/1992, electromagnetic tolerance) and meets legal requirements.

To guarantee the electromagnetic tolerance you must take the following precautions:

- Connect the transformer only to an approved mains socket installed by an authorised electrician.
- Make no changes to the original parts and accurately follow the instructions, print layout and circuit diagram included with this manual.
- Use only original spare parts if you have to repair the module.

Information: Speed mode

Digital control units for DCC format can send 14, 28 or 128 speed levels depending on the model and the settings. The number of speed levels sent by the digital control unit (= speed mode) must be set at the decoder as well. Otherwise the performance of the locomotive may be incorrect.

Information: Configuration variables (CVs)

You can set the so-called configuration variables of the decoder from the central unit. The programming of the variables allows the adjustment of the decoder to the particular driving characteristics of the locomotive and to the individual needs of the user.

The configuration variables are saved in the decoder and are also preserved if the locomotive is switched off. Changing the configuration variables is possible at any time from the digital control unit.

The configuration variables for the DCC format are standardised. The variables that can be set depend on the decoder type.

Operation overview

The decoder is designed for operation in DCC format and can be adjusted to one of 127 basic addresses or to one of 10.239 extended addresses. It is designed to be controlled from digital control units that are set on the 14-, 28 or the 128-speed mode.

The decoder can be programmed individually by setting the configuration variables. It is possible to set all configuration variables with central units which support the CV-programming. With central units which only support the so-called register-programming the number of the configuration variables that can be set is restricted.

The configuration variables of the LD-G-7 / LD-W-7

The following configuration variables (CVs) can be set from the digital control unit:

- Basic address (CV#1)
- Starting voltage (CV#2)
- Acceleration rate (CV#3)
- Braking rate (CV#4)
- Maximum voltage (CV#5) *
- Version (CV#7) – read only
- Manufacturer identification (CV#8) - read only
- PWM-Period (CV 9) *
- Extended address (CV#17 und CV#18) *
- Configuration data (CV#29)
- Utilisation and setting of output X4 and X5 (CV#56) *: Lighting according to the direction of travel for forward direction or constant light / F2 to switch the lighting according to the direction of travel.

* Not possible with central units with register programming!

Velocity characteristic

The decoder can be adjusted to the driving characteristics of the motor and the characteristic speed of the locomotive type, by setting the starting velocity and the maximum velocity. From the starting velocity and the maximum velocity the decoder generates a linear velocity characteristic.

The operating voltage of the locomotive motor at speed level 1 is set by adjusting the starting velocity. Normally the motor voltage is adjusted so that the locomotive just starts to run at speed level 1.

The operating voltage of the locomotive motor at speed level 14, 28 or 128 is set by adjusting the maximum velocity. The adjustment should be such that the locomotive reaches the desired maximum speed at the highest speed level.

Driving of the motor

With the factory settings the motor is driven with a PWM of 125 Hz. In case of a noisy or unquiet operation of the motor, the PWM frequency may be adjusted by changing the values of CV#9.

Shunting gear / Function F3

The function F3 allows the switching to the shunting gear. In the shunting gear mode the velocity of all speed levels is reduced to ca. 50 % compared to the standard velocity. This facilitates a fine speed control for shunting operations at low speeds.

Acceleration and brake delay

It is possible to program the acceleration and brake delay individually via the central unit.

The locomotive decoder outputs

The locomotive decoder has two outputs that can be connected with the following accessories.

Output X5: Lighting for forward direction.

Output X4: Optional accessories to be switched via function F2 **or**:
Lighting for reverse direction.

Function F0 (Light)

The lights can be switched from the digital control unit. You can either set the lighting according to the direction of travel or a fixed light for both directions of travel by programming the configuration variable CV 56.

Function F2

If the configuration variable CV 56 is programmed accordingly, the function F2 allows an optional accessory, connected to the output X4, to be switched on or off. If lighting for reverse direction is programmed for the output X4, the function F2 has no effect on this output.

Technical specifications

Data format	DCC
Supply voltage	12-24 Volt digital voltage
Current consumption (without connected loads)	approx. 10 mA
Max. current for motor	800 mA
Max. current per function output	100 mA
Max. total current	1.000 mA
Protected to	IP 00
Ambient temperature in use	0 - + 60° C
Ambient temperature in storage	-10 - + 80° C
Comparative humidity allowed	max. 85 %
Dimensions	approx. 19 x 17 x 5 mm
Weight	approx. 1 g

Checking the package contents

Check the contents of the package for completeness immediately after unpacking:

- one decoder, with or without soldered connecting wires or soldered NEM 652 interface connector, depending on the version.
- one manual.

N.B. For technical reasons it is possible that the PCB is not completely inserted. This is not a fault.

Required tools and materials

Make sure you have the following tools, equipment and materials ready for use:

- an electronic soldering iron (max. 30 Watt) with a fine tip,
- a soldering iron stand,
- a tip-cleaning sponge,
- a heat-resistant mat,
- a small side cutter and wire stripper,
- a pair of tweezers,
- tin solder (0,5 mm. diameter),
- wire (diameter: $> 0,05 \text{ mm}^2$ for all connections).

Safe and correct soldering



Caution:

Incorrect soldering can cause dangers through fires and heat. Avoid these dangers by reading and following the directions given in the chapter **Safety instructions**. If you have had training in soldering you can skip this chapter.

- Use a small soldering iron with max. 30 Watt. Keep the soldering tip clean so the heat of the soldering iron is applied to the solder point effectively.
- Only use tin solder SN 60 Pb (i.e. 60 % tin, 40 % lead) with rosin-based flux.
- When soldering electronic circuits never use soldering-water or soldering grease. They contain acids that can corrode components and copper tracks.
- Solder quickly: holding the iron on the joints longer than necessary can destroy components and can damage copper tracks or soldering eyes.
- Apply the soldering tip to the soldering spot in such a way that the wire and the soldering eye are heated at the same time. Simultaneously add solder (not too much). As soon as the solder becomes liquid take it away. Hold the soldering tip at the spot for a few seconds so that the solder flows into the joint, then remove the soldering iron.
- The joint should be held still for about 5 seconds after soldering. A glossy and perfect soldering spot should remain.
- To make a good soldering joint you should use a clean and unoxidised soldering tip. Clean the soldering tip with a damp piece of cloth, a damp sponge or a piece of silicon cloth.
- After soldering check (preferably with a magnifying glass) tracks for accidental solder bridges and short circuits. This would cause faulty operation or, in the worst case, permanent damage. You can remove excess solder by putting a clean soldering tip on the spot. The solder will become liquid again and flow from the soldering spot to the soldering tip.

Mounting the locomotive decoder

Open the locomotive housing. Locate the position for the decoder. Disconnect the motor from the rail current collector respectively the change-over switch from the motor and rails if you have a locomotive with electronic change-over switch. The change-over switch is no longer necessary, you can remove it.



Caution:

The interference suppression devices mounted to the motor or the connecting wire must not be removed! Motor and interference suppression devices are one unit. If even one part is removed, it can cause extreme interference!

Connecting the LD-G-7

Follow the connections diagrams (fig. 1)! Solder the two connections to the current collectors to the points X2 and X3. These two connections can be exchanged without effecting functionality. Solder the connections to the motor at the points X10 and X11.

Connecting the LD-W-7

Follow the connections diagrams (fig. 2)! Solder the connection to the slider at point X2 and the connection to the housing to point X3. These two connections can be exchanged without effecting functionality. Solder the connections to the motor at the points X6, X10 and X11.

Connecting the lighting

Follow the connections diagrams (fig. 1, 2 and 3)!

Disconnect any existing diodes in the leads to the lamps. Connect the lamps for forward motion to X5 and the lamps for reverse to point X4. If the lamps are already connected with one side to locomotive ground, the connection is complete. If not, connect the second side of the lamps to the return conductor (point X1 or X6).

 **Caution:**

The return conductor for all functions (point X1 or X6) must under no circumstances be connected to locomotive ground. Possible short circuit! The locomotive decoder will be damaged in operation.

Tip: If the second side of the lamps is connected to locomotive ground the lamps often flicker in operation. You can avoid the flickering of the lamps if you connect the second side to the return conductor (point X1 or X6) instead of locomotive ground.

 **Caution:**

If you connect the lamps to the return conductor for all functions (point point X1 or X6), the lamps must be insulated. The lamps must not make contact with metal parts of the locomotive. Possible short circuit! The locomotive decoder will be damaged in operation.

Tip: Before starting to program the locomotive decoder you should connect the motor to the decoder. Otherwise there is no confirmation signal from the central unit.

Connecting the LEDs

The function outputs of the locomotive decoder switch against decoder ground. For that reason you must connect the cathode (-) of the LED to the output of the relevant function.

 **Caution:**

If you use light-emitting diodes (LEDs) you must always operate them via a series resistor.

LEDs are available in many different models. There are LEDs with 2-5 mA, but also LEDs with 15-30 mA power consumption. The series resistor limits the current flow of the LED and will need to be calculated for each model. Ask for the max current rating when buying your LEDs.

You can connect up to 5 LEDs in parallel to each output. In this case every LED must have a series resistor of its own. If you connect several LEDs to one output in series, only one series resistor is needed. The

number of LEDs connected in series to one output depends on the digital voltage.

You can determine the number of the LEDs that can be connected in series to one output from the following formula:

$$\boxed{(\text{number of LEDs} + 2) \times 1,5 < \text{digital voltage}}$$

Fixing the locomotive decoder

After completing all connections fix the locomotive decoder with double-sided adhesive tape, for example.

Using a NEM 652 interface connector

Some locomotives already have an NEM 652 interface connector mounted. Using a convenient connecting plug you save disconnecting the connections and you do not need to solder at the locomotive.

The list below shows how to connect the contacts of the interface connector to the connecting points of the locomotive decoder.

Contact	Connection	Colour of cable	Connecting points
1	Motor connection 1	orange	X11
2	Lighting back (-)	yellow	X4
3	Not used or F1	green	---
4	Power supply left	black	X3
5	Motor connection 2	grey	X10
6	Lighting front (-)	white	X5
7	Common conductor for all functions (+)	blue	X6
8	Power supply right	red	X2

Programming the locomotive decoder

The locomotive decoder is programmed from the digital central. See chapter in the manual of your digital control unit where the programming of configuration variables (CVs) is explained.

You can programm or read out the following locomotive decoder variables:

NB. With central units with register-programming it is only possible to program the variables CV#1 to CV#4 (= register 1 to 4) and CV#29 (= register 5).

CV-name	CV-no.	Input value / (State of delivery)	Remarks
Basic address	1	1 ... 127 (3)	
Starting voltage	2	0 ... 255 (10)	= The voltage to be output to the motor at speed level 1. The value "0" corresponds to 0 Volt, the value "255" to the max. voltage.
Acceleration rate	3	1 ... 255 (1)	= Length of the delay before the switching to the next higher speed level when the locomotive is accelerating. The delay is calculated as follows: (value of CV#3) x 0,9 sec. / number of speed levels
Braking rate	4	1 ... 255 (1)	= Length of the delay before the switching to the next lower speed level when the locomotive is braking. The delay is calculated as described in CV#3.

CV-name	CV-no.	Input value / (State of delivery)	Remarks																		
Maximum voltage	5	0 ... 255 (0)	= The voltage to be output to the motor at the highest speed level. The value "2" corresponds to 0,8 %, the value "255" to 100 % of the max. voltage.																		
Version	7	---	Read only!																		
Manufacturer	8	--- (62)	Read only!																		
Reset	8	0 ... 255	Any value restores the settings in state of delivery.																		
PWM-period	9	160.. 167 (164)	<table border="0"> <tr> <td>value of CV#9</td> <td>frequency</td> </tr> <tr> <td>160</td> <td>2 kHz</td> </tr> <tr> <td>161</td> <td>1 kHz</td> </tr> <tr> <td>162</td> <td>500 Hz</td> </tr> <tr> <td>163</td> <td>250 Hz</td> </tr> <tr> <td>164</td> <td>125 Hz</td> </tr> <tr> <td>165</td> <td>62 Hz</td> </tr> <tr> <td>166</td> <td>31 Hz</td> </tr> <tr> <td>167</td> <td>15 Hz</td> </tr> </table>	value of CV#9	frequency	160	2 kHz	161	1 kHz	162	500 Hz	163	250 Hz	164	125 Hz	165	62 Hz	166	31 Hz	167	15 Hz
value of CV#9	frequency																				
160	2 kHz																				
161	1 kHz																				
162	500 Hz																				
163	250 Hz																				
164	125 Hz																				
165	62 Hz																				
166	31 Hz																				
167	15 Hz																				
Extended adress	17 18	1 ... 10239 (-)																			
Configuration data	29	0, 1, 2, 3, 32, 33, 34 or 35 (2))	This data is set by entering the sum of the numerical values.																		
			Numerical value																		
			Direction "standard"	0																	
			Reverse direction	1																	
			14 speed levels	0																	
			28 or 128 speed levels	2																	
Basic adress	0																				
Extended adress	32																				

CV-name	CV-no.	Input value / (State of delivery)	Remarks
Utilization and setting of output X4 and X5	56	0,1,2 or 3 (3)	This data is set by entering the sum of the numerical values.
			Numerical value
			Constant light 0
			Lighting according to direction of travel 1
			Second accessory switched via F2 0
			Lighting for reverse direction 2

Improvement of the driving characteristics

Locomotives with especially high current consumption or track sections with bad contacts (e.g. some types of points) may give an unsatisfactory performance. You can improve the locomotive performance by soldering a capacitor 100 μ F / 35 V between X1 and X7 (see fig. 1 and 2).

FAQ

- Parts are getting very hot and/or start to smoke.



Disconnect the system from the mains immediately!

Possible cause: one or more connections are soldered incorrectly.

→ Check the connections.

Possible cause: The connection of the motor is connected to locomotive ground. → Disconnect the connection from locomotive ground.

- The locomotive lighting does not correspond to its direction of travel.

Possible cause: The forward and backward light connections have been exchanged. → Check the connections.

Possible cause: The connections of the motor to the points X11 and X12 have been exchanged. → Exchange the connections.

- The lighting goes on and off when the speed levels are turned up or the lighting cannot be switched on or off.

Possible cause: The speed mode of the decoder and the digital control unit do not correspond. Example: The central is set to the mode 28 speed levels, but the decoder to the mode 14 speed levels. → Change the speed mode at the central and / or at the decoder.

If you cannot find the problem, please return the decoder for repair (address on the cover page).

Manufacturer's note

According to DIN VDE 0869, the person who brings the circuit into operation by extension or mounting into a housing is the manufacturer of the product. If he sells the product to another person he is responsible for passing on all the relevant papers and to give his name and address.

Certification

This product conforms with the EC- directive 89/336/EWG on electromagnetic radiation and is therefore CE certified.

Conditions of warranty

This product is guaranteed for two years. The warranty includes the correction of faults which can be proved to be due to material failure or factory flaw. We guarantee the adherence to the technical specifications of the circuit when assembled and connected according to the manual.

Other claims are excluded. By law, we are not responsible for damages or secondary damages in connection with this product. We retain the right to repair, make improvements, supply spare parts or return the purchase price.

The following invalidate the warranty:

- using an unsuitable soldering iron, solder containing liquid acids or similar,
- if damage is caused by not following the instructions in this manual, if the module has been altered and repair attempts have failed,
- if arbitrary changes in the circuit are made,
- if additional components are added which are not described in the manual,
- if the copper tracks or soldering eyes are damaged,
- if damage occurs due to an overload of the module,
- if connected to a incorrect voltage or current,
- if damaged by other persons,
- if damaged by faulty operation or if damaged by careless use or abuse,
- if damaged by touching components before electrostatic discharging of the hands.

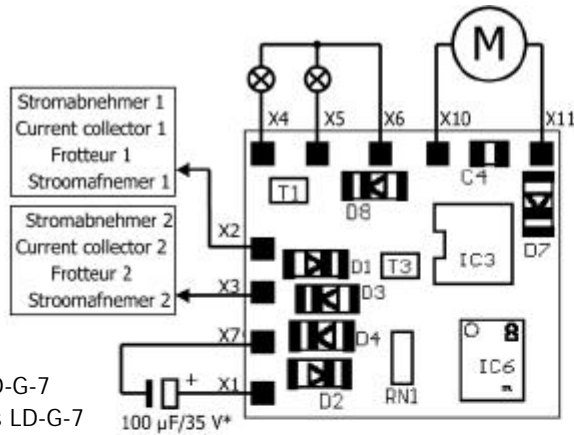

Fig. 1:

Anschluß LD-G-7
Connections LD-G-7
Connexion LD-G-7
Aansluiten LD-G-7

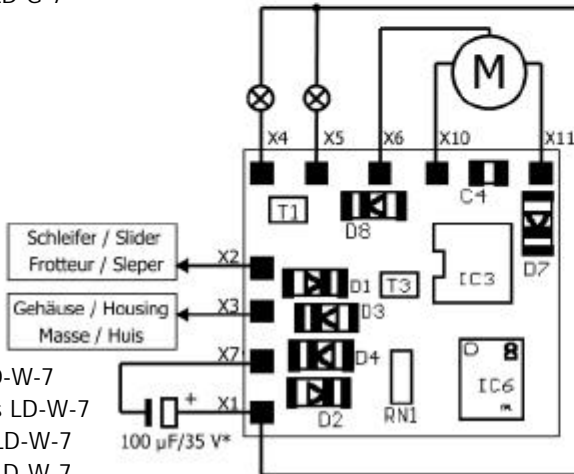
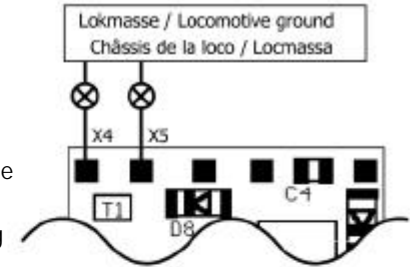

Fig. 2:

Anschluß LD-W-7
Connections LD-W-7
Connexion LD-W-7
Aansluiten LD-W-7

Fig. 3:

Anschluß der Beleuchtung
an Lokmasse
Connection of the lighting
to locomotive ground
Raccordement de l'éclairage
via le châssis de la loco
Verbinding van de verlichting
met de locmassa



- X1 **LD-W-7:** Rückleiter für alle Funktionen / Return conductor for all functions / Pole commun des fonctions / Retourleiding voor alle functie
- X4 Beleuchtung Rückwärtsfahrt oder F2 / Lighting reverse direction or F2 / Feux marche arrière ou F2 / Verlichting achteruitrijden of F2
- X5 Beleuchtung Vorwärtsfahrt / Lighting forward direction / Feux marche avant / Verlichting vooruitrijden
- X6 **LD-G-7:** Rückleiter für alle Funktionen / Return conductor for all functions / Pole commun des fonctions / Retourleiding voor alle functie
LD-W-7: Rückleiter des Motors (schwarzes Kabel) / Return conductor of the motor (black cable) / Retour du moteur (fil noir) / Retourleiding van de motor (zwarte draad)
- X10 Feldwicklung "vor" des Motors / "Forwards" field winding of the motor / Bobinage d'induit "marche avant" du moteur / Veldwikkling "heen" van de motor
- X11 Feldwicklung "zurück" des Motors / "Backwards" field winding of the motor / Bobinage d'induit "marche arrière" du moteur / Veldwikkling "terug" van de motor

* falls erforderlich / If necessary / si necessaire / indien noodzakelijk

Aktuelle Informationen und Tipps:

Information and tips:

Informations et conseils:

Actuele informatie en tips:

<http://www.tams-online.de>

Garantie und Service:

Warranty and service:

Garantie et service:

Garantie en service:

Tams Elektronik GmbH

Rupsteinstraße 10

D-30625 Hannover

fon: ++49 (0)511 / 55 60 60

fax: ++49 (0)511 / 55 61 61

e-mail: modellbahn@tams-online.de