



LD-G-8

Lastgeregelter Lokdecoder
für Gleichstrommotoren
DCC-Format

Locomotive Decoder
with load control for
DC engines - DCC format

Décodeur avec compensation de
charge pour locomotive avec
moteur continu - Format DCC

Lastgeregelde Locdecoder
voor gelijkstroommotoren
DCC-format

Art.-Nr. 22-01-065
Art.-Nr. 22-01-066

Anleitung

Manual

Mode d'emploi

Handleiding



Table of contents

How to use this manual	26
Intended use	26
Safety instructions	27
EMC declaration	29
Information: Speed mode	29
Information: Configuration variables (CVs)	29
Operation overview	30
Technical specifications	34
Checking the package contents	34
Required tools and materials	34
Safe and correct soldering	35
Mounting the locomotive decoder	36
Programming the locomotive decoder	39
Improvement of the driving characteristics	43
FAQ	43
Manufacturer's note	43
Certification	44
Conditional warranty	44
Connections (Fig. 1 and 2)	I
Circuit Diagram (Fig. 3)	II
(Pages I to II in the centre of this handbook are removeable.)	

How to use this manual

If you have no specialist technical training, this manual gives step-by-step instructions for safe and correct fitting of the module, and operation. Before you start, we advise you to read the whole manual, particularly the chapter on safety instructions and the FAQ chapter. You will then know where to take care and how to prevent mistakes which take a lot of effort to correct.

Keep this manual safely so that you can solve problems in the future. If you pass the module on to another person, please pass on the manual with it.

Intended use



Caution:

Integrated circuits are very sensitive to static electricity. Do not touch components without first discharging yourself. Touching a radiator or other grounded metal part will discharge you.

The module can be used according to the specifications of this manual in a model railway. Mounted in a model railway locomotive with d.c motor it evaluates the DCC format data sent by the digital central unit to its address. The decoder controls the vehicle performance (velocity, direction of travel, acceleration) and switches the four function outputs, which can be variously assigned to the functions keys.

The module should not be assembled or operated by children under the age of 14.

Reading, understanding and following the instructions in this manual are mandatory for the user.

Any other use is inappropriate and invalidates any guarantees.

Safety instructions

Mechanical hazards

Cut wires can have sharp ends and can cause serious injuries. Watch out for sharp edges when you pick up the PCB.

Visibly damaged parts can cause unpredictable danger. Do not use damaged parts: recycle and replace them with new ones.

Electrical hazards

- Touching powered, live components,
- touching conducting components which are live due to malfunction,
- short circuits,
- connecting the circuit to another voltage than specified,
- impermissibly high humidity,
- condensation build up

can cause serious injury due to electrical shock. Take the following precautions to prevent this danger:

- Never perform wiring on a powered module.
- Mounting the module should only be done in closed, clean, dry rooms. Beware of humidity.
- Only use low power for this module as described in this manual and only use certified transformers.
- Connect transformers and soldering irons only in approved mains sockets installed by an authorised electrician.
- Observe cable diameter requirements.
- After condensation build up, allow a minimum of 2 hours for dispersion.
- Use only original spare parts if you have to repair the module.

Fire risk

Touching flammable material with a hot soldering iron can cause fire, which can result in injury or death through burns or suffocation. Connect your soldering iron or soldering station only when actually needed. Always keep the soldering iron away from inflammable materials. Use a suitable soldering iron stand. Never leave a hot soldering iron or station unattended.

Thermal danger

A hot soldering iron or liquid solder accidentally touching your skin can cause skin burns. As a precaution:

- use a heat-resistant mat during soldering,
- always put the hot soldering iron in the soldering iron stand,
- point the soldering iron tip carefully when soldering, and
- remove liquid solder with a thick wet rag or wet sponge from the soldering tip.

Dangerous environments

A working area that is too small or cramped is unsuitable and can cause accidents, fires and injury. Prevent this by working in a clean, dry room with enough freedom of movement.

Other dangers

Children can cause any of the accidents mentioned above because they are inattentive and not responsible enough. Children under the age of 14 should not be allowed to work with this module.

Little children can swallow small components with sharp edges, with fatal results! Do not allow components to reach small children.

In schools, training centres, clubs and workshops, assembly, mounting and operation must be supervised by qualified personnel.

In industrial institutions, health and safety regulations applying to electronic work must be adhered to.

EMC declaration

This product is developed in accordance with the European standards EN 55014 and EN 50082-1, tested corresponding to the EC - directive 89/336/EEG (EMVG of 09/11/1992, electromagnetic tolerance) and meets legal requirements.

To guarantee the electromagnetic tolerance you must take the following precautions:

- Connect the transformer only to an approved mains socket installed by an authorised electrician.
- Make no changes to the original parts and accurately follow the instructions, print layout and circuit included with this manual.
- Use only original spare parts if you have to repair the module.

Information: Speed mode

Digital control units for DCC format can send 14, 28 or 128 speed levels depending on the model and the settings. The number of speed levels sent by the digital control unit (= speed mode) must be set at the decoder as well. Otherwise the performance of the locomotive may be incorrect.

Information: Configuration variables (CVs)

You can set the so-called configuration variables of the decoder from the central unit. The programming of the variables allows the adjustment of the decoder to the particular driving characteristics of the locomotive and to the individual needs of the user.

The configuration variables are saved in the decoder and are also preserved if the locomotive is switched off. Changing the configuration variables is possible at any time from the digital control unit.

The configuration variables for the DCC format are standardised. The variables that can be set depend on the decoder type.

Operation overview

The decoder LD-G-8 is designed for operation in DCC format and can be adjusted to one of 127 basic addresses or to one of 10.239 extended addresses. It is designed to be controlled from digital control units that are set on the 14-, 28 or the 128-speed mode.

The decoder can be programmed individually by setting the configuration variables. It is possible to set all configuration variables with central units which support the CV-programming. With central units which only support the so-called register-programming the number of the configuration variables that can be set is restricted.

The configuration variables of the LD-G-8

The following configuration variables (CVs) can be set from the digital control unit:

- Basic address (CV#1)
- Starting voltage (CV#2)
- Acceleration rate (CV#3)
- Braking rate (CV#4)
- Maximum voltage (CV#5) *¹
- Version (CV#7) – read only *¹
- Manufacturer identification (CV#8) - read only *¹
- Extended address (CV#17 und CV#18) *¹
- Configuration data 1 (CV#29)
- Assignment of the outputs X1 to X4 to the function keys F5 to F8 (CV#39 to 42) *¹
- Configuration data 2 (CV#49) *¹
- Dimming of the outputs X1 to X4 (CV#50 to C53) *¹
- Proportional component of the load control "KP" (CV#54) *¹
- Assignment of the outputs X1 to X4 to the function keys F0 to F4 (CV#55 to 58) *¹

- Integral component of the load "KI" (CV#59) *¹
 - Effects for the outputs X1 to X4 (CV#60 to 63) *¹
 - Differential component of the load control "KD" (CV#64) *¹
 - Alternative velocity characteristic for mode 28 speed levels (CV#67 to 94) *¹
- *¹ Not possible with central units with register programming!

Driving of the motor

The motor is driven with a PWM of 32 kHz. This guarantees a soft and constant run of the motor. The decoder may also be used with coreless (Faulhaber) motors as well.

Load control

At constant motor voltage, additional loads (e.g. running up a gradient, coupled carriages) cause the locomotive to slow down or even come to a standstill. If the load control is active the motor voltage varies to keep the locomotive operating at constant velocity at a given speed level, independent of additional loads.

It is possible to switch on and off the load control by varying a CV-variable of the decoder. The parameters of the load control may be altered as well.



Attention:

For most locomotives you will achieve good driving characteristics with the factory settings. Incorrect of the load control parameter settings deteriorate the driving characteristics of the motor considerably. Therefore you should first check the locomotive with the preset values and modify the parameters of the load control only step-by-step.

Parameters of the load control: The load control is determined by three parameters which have to be coordinated in order to achieve optimal driving characteristics. Each of the load control parameters is assigned to a configuration variable. The parameters are:

KP: The proportional component of the load control ensures the difference between the set and the present value being as small as possible. It cannot have the value „0“ at any time.

KI: The integral component of the load control ensures the remaining difference between the set and the present value being reduced to 0.

KD: The differential component of the load control ensures that the control is not converted too quickly. Shaking and vibrating would be the consequence.

Velocity characteristic

The decoder can be adjusted to the driving characteristics of the motor and the characteristic speed of the locomotive type, by setting the starting velocity and the maximum velocity. From the starting velocity and the maximum velocity the decoder generates a linear velocity characteristic.

The operating voltage of the locomotive motor at speed level 1 is set by adjusting the starting velocity. Normally the motor voltage is adjusted so that the locomotive just starts to run at speed level 1.

The operating voltage of the locomotive motor at speed level 14, 28 resp. 128 is set by adjusting the maximum velocity. The adjustment should be such that the locomotive reaches the desired maximum speed at the highest speed level.

When the speed level mode is set to 28 speed levels, it is possible to assign any motor voltage to all of the 28 speed levels as an alternative to the linear velocity characteristic. This allows the programming of a velocity characteristic which adjusts the individual driving characteristics of the motor. The set values are saved in the alternative velocity table.

Shunting gear

In the speed modes 14 and 28, it is possible to switch into the shunting gear mode via a function key, when so programmed. In the shunting gear mode, the velocity of all speed levels is reduced to approx. 50 % compared to the set velocity.

Acceleration and brake delay

It is possible to program the acceleration and brake delay individually via the central unit.

Emergency stop

By setting a CV-variable it is possible to adjust how an emergency stop is carried out. There are the following possibilities:

- no emergency stop possible,
- emergency stop at change of direction and / or
- emergency stop by operating of F1.

Function outputs

The decoder has four function outputs which can be switched on and off via the function keys „function“ and / or the auxiliary function keys F0 to F8. They are available to connect optional accessories (e.g. lighting, smoke generator, sound module, electric coupling).

You can assign the function keys to the function outputs freely. It is possible to assign several function keys to one function output.

Effects of the function outputs

It is possible to set the following effects for all function outputs individually:

- Irregular flickering. Example of use: Flickering of the boiler fire by steam engines.
- Strobe (flashing). Example of use: American locomotives with that kind of lighting.
- MARS light (swelling of the brightness). Example of use: American locomotives with that kind of lighting.
- Switching on and off depending on the direction of travel.
- Flashing with a frequency of 2 Hz with two phases which are out-of-phase by 180 degrees. Example of use: individual flash lights or alternating flash lights.
- Flashing with a frequency of 1 Hz.

Technical specifications

Data format	DCC
Supply voltage	12-24 Volt digital voltage
Current consumption (without connected loads)	approx. 10 mA
Max. current for motor	1.000 mA
Max. current per function output	500 mA
Max. total current	1.500 mA
Protected to	IP 00
Ambient temperature in use	0 - + 60° C
Ambient temperature in storage	-10 - + 80° C
Comparative humidity allowed	max. 85 %
Dimensions	approx. 27,5 x 16,5 x 5,5 mm
Weight	approx. 5 g

Checking the package contents

Check the contents of the package for completeness immediately after unpacking:

- one decoder, with or without soldered connecting wires resp. soldered NEM 652 interface connector, depending on the version.
- one manual.

N.B. For technical reasons it is possible that the PCB is not completely inserted. This is not a fault.

Required tools and materials

Make sure you have the following tools, equipment and materials ready for use:

- an electronic soldering iron (max. 30 Watt) with a fine tip,
- a soldering iron stand,

- a tip-cleaning sponge,
- a heat-resistant mat,
- a small side cutter and wire stripper,
- a pair of tweezers,
- tin solder (0,5 mm. diameter),
- wire (diameter: $\geq 0,05 \text{ mm}^2$ for all connections).

Safe and correct soldering



Caution:

Incorrect soldering can cause dangers through fires and heat. Avoid these dangers by reading and following the directions given in the chapter **Safety instructions**. If you have had training in soldering you can skip this chapter.

- Use a small soldering iron with max. 30 Watt. Keep the soldering tip clean so the heat of the soldering iron is applied to the solder point effectively.
- Only use tin solder SN 60 Pb (i.e. 60 % tin, 40 % lead) with rosin-based flux.
- When soldering electronic circuits never use soldering-water or soldering grease. They contain acids that can corrode components and copper tracks.
- Solder quickly: holding the iron on the joints longer than necessary can destroy components and can damage copper tracks or soldering eyes.
- Apply the soldering tip to the soldering spot in such a way that the wire and the soldering eye are heated at the same time. Simultaneously add solder (not too much). As soon as the solder becomes liquid take it away. Hold the soldering tip at the spot for a few seconds so that the solder flows into the joint, then remove the soldering iron.
- The joint should be held still for about 5 seconds after soldering. A glossy and perfect soldering spot should remain.

- To make a good soldering joint you should use a clean and unoxidised soldering tip. Clean the soldering tip with a damp piece of cloth, a damp sponge or a piece of silicon cloth.
- After soldering check (preferably with a magnifying glass) tracks for accidental solder bridges and short circuits. This would cause faulty operation or, in the worst case, permanent damage. You can remove excess solder by putting a clean soldering tip on the spot. The solder will become liquid again and flow from the soldering spot to the soldering tip.

Mounting the locomotive decoder

Open the locomotive housing. Locate the position for the decoder. Disconnect the motor from the rail current collector.

Mounted to the motor there are interference suppression devices, consisting of capacitors and chokes. Disconnect the interference suppression devices.

Follow the connection diagram fig. 1 and fig. 2.

Solder the connections from the rail current collectors at the points X8 and X9 (back of the locomotive decoder). The assignment of the connecting wires is not important.

Next solder the connections from the motor at the points X6 and X7 (back of the locomotive decoder).

Connecting the lighting and other accessories

Disconnect any existing diodes in the leads to the lamps. Follow the connection diagram fig. 1 and fig. 2.

Connect the lamps and other accessories to the function outputs (X1 to X4) on the front of the decoder. The assignment of the function outputs to the function keys will be made when programming the decoder.

If the lamp or the accessory is already connected with one side to locomotive ground, the connection is complete. If not, connect the

second side of the lamp or the accessory to the return conductor of the decoder (point X5).

If you want to use the decoder factory settings, you have to connect the lighting and the accessories as follows:

Front lighting: X4

Back lighting: X3

Accessory to be switched via F1: X1

Accessory to be switched via F2: X2



Caution:

If you connect the loads to the return conductor for all functions (point X5), the load must be insulated. The loads should not make contact with metal parts of the locomotive. Possible short circuit! The locomotive decoder will be damaged in operation.



Caution:

The return conductor for all functions (point X5) must under no circumstances be connected to locomotive ground. Possible short circuit! The locomotive decoder will be damaged in operation.

Tip: Before starting to program the locomotive decoder you should connect the motor to the decoder. Otherwise there is no confirmation signal from the central unit.

Connecting the LEDs

The function outputs of the locomotive decoder switch against decoder ground. For that reason you must connect the cathode (-) of the LED to the output of the relevant function.



Caution:

If you use light-emitting diodes (LEDs) you must always operate them via a series resistor.

LEDs are available in many different models. There are LEDs with 2-5 mA, but also LEDs with 15-30 mA power consumption. The series

resistor limits the current flow of the LED and will need to be calculated for each model. Ask for the max current rating when buying your LEDs. You can connect up to 5 LEDs in parallel to each output. In this case every LED must have a series resistor of its own. If you connect several LEDs to one output in series, only one series resistor is needed. The number of LEDs connected in series to one output depends on the digital voltage.

You can determine the number of the LEDs that can be connected in series to one output from the following formula:

$$\boxed{(\text{number of LEDs} + 2) \times 1,5 < \text{digital voltage}}$$

Fixing the locomotive decoder

After completing all connections fix the locomotive decoder with double-sided adhesive tape, for example.

Using a NEM 652 interface connector

Some locomotives already have an NEM 652 interface connector mounted. Using a convenient connecting plug you save disconnecting the connections and you do not need to solder at the locomotive.

The list below shows how to connect the contacts of the interface connector to the connecting points of the locomotive decoder.

Contact	Connection	Colour of cable	Connecting points
1	Motor connection 1	orange	X7
2	Lighting back (-)	yellow	X3
3	Not used or F1	green	X1
4	Power supply left	black	X8
5	Motor connection 2	grey	X6
6	Lighting front (-)	white	X4
7	Common conductor for all functions (+)	blue	X5
8	Power supply right	red	X9

Programming the locomotive decoder

The locomotive decoder is programmed from the digital central. See chapter in the manual of your digital control unit where the programming of configuration variables (CVs) is explained.

You can programm resp. read out the following locomotive decoder variables:

NB. With central units with register-programming it is only possible to program the variables CV#1 to CV#4 (= register 1 to 4) and CV#29 (= register 5).

*2 Tip: You program the configuration variables CV#29, CV#39 to 42, CV# 49, CV#55 to 58 and CV#60 to 63 by entering the sum of the numerical values which are assigned to the desired parameters.

CV-name	CV-no.	Input value / (State of delivery)	Remarks
Basic address	1	1 ... 127 (3)	
Starting voltage	2	0 ... 255 (10)	= The voltage to be output to the motor at speed level 1. The value "0" corresponds to 0 Volt, the value "255" to the max. voltage.
Acceleration rate	3	0 ... 255 (16)	= Length of the delay before the switching to the next higher speed level when the locomotive is accelerating. The delay is calculated as follows: (value of CV#3) x 0,9 sec. / number of speed levels

CV-name	CV-no.	Input value / (State of delivery)	Remarks
Braking rate	4	0 ... 255 (16)	= Length of the delay before the switching to the next lower speed level when the locomotive is braking. The delay is calculated as described in CV#3.
Maximum voltage	5	0 ... 255 (0)	= The voltage to be output to the motor at the highest speed level. The value "2" corresponds to 0,8 %, the value "255" to 100 % of the max. voltage.
Version	7	---	Read only!
Manufacturer	8	---	Read only!
Reset	8	0 ... 255	Any value restores the settings in state of delivery.
Extended adress	17 18	1 ... 10239 (-)	
Configuration data 1	29	(2)	Numerical value *2
			Direction "standard" 0
			Reverse direction 1
			14 speed levels 0
			28 or 128 speed levels 2
			Linear velocity characteristic 0
			Alternative velocity characteristic 16
Basic adress 0			
Extended adress 32			

CV-name	CV-no.	Input value / (State of delivery)	Remarks
Assignment F5 – F8 to the outputs:		0 ... 15 (0)	Numerical value * ² Operation with:
X4	39		--- 0
X3	40		function key F5 1
X1	41		function key F6 2
X2	42		function key F7 4
			function key F8 8
Configuration data 2	49	0 ... 127 (1)	Numerical value * ²
			Load control active 1
			Emergency stop at change of direction 2
			Emergency stop at F1 4
			Shunting gear mode at F1 8
			Shunting gear mode at F2 16
			Shunting gear mode at F3 32
Shunting gear mode at F4 64			
Dimming of the outputs:		0 ... 63 (63)	= The voltage that is applied to the output.
X4	50		The value "1" corresponds to the minimum, „63" to the maximum voltage.
X3	51		
X1	52		
X2	53		
Parameter of load control KP	54	0 ... 255 (25)	= Proportional component of the load control.

CV-name	CV-no.	Input value / (State of delivery)	Remarks
Assignment F0 – F4 to the outputs:		0 ... 31 (0)	Numerical value * ² Operation with:
X4	55		--- 0 function key F1 1
X3	56		function key F2 2
X1	57		function key F3 4
X2	58		function key F4 8 function key F0 16
Parameter of load control KI	59	0 ... 255 (5)	= Integral component of the load control.
Effects for the outputs:		0 ... 255 (0)	Numerical value * ²
X4	60		Flickering active 1
X3	61		Strobe active 2
X1	62		MARS light active 4
X2	63		at backward motion inactive 8 at forward motion inactive 16
			Flashing 2 Hz phase A 32
			Flashing 2 Hz phase B 64
			Flashing 1 Hz 128
Parameter of load control KD	64	0 ... 255 (48)	= Differential component of the load control
Alternative velocity characteristic (only with mode 28 speed levels)	67 . . . 94	0 ... 255	= The velocity table for the alternative velocity characteristic. Any motor voltage can be assigned to all of the 28 speed levels. The value "0" corresponds to a voltage of „0“, „255“ to the maximum voltage.

Improvement of the driving characteristics

Locomotives with especially high current consumption or track sections with bad contacts (e.g. some types of points) may give an unsatisfactory performance. You can improve the locomotive performance by soldering a capacitor 100 μF / 35 V between X10 and X11 (see fig. 2).

FAQ

- Parts are getting very hot and/or start to smoke.
Tip: The ICs 4 and 6 may warm up to 45 °C in operation. This does not affect the functioning of the decoder.



Disconnect the system from the mains immediately!

Possible cause: one or more connections are soldered incorrectly.

→ Check the connections.

Possible cause: The connection of the motor is connected to locomotive ground. → Disconnect the connection from locomotive ground.

- The lighting goes on and off when the speed levels are turned up or the lighting cannot be switched on or off.
Possible cause: The speed mode of the decoder and the digital control unit do not correspond. Example: The central is set to the mode 28 speed levels, but the decoder to the mode 14 speed levels. → Change the speed mode at the central and / or at the decoder.

If you cannot find the problem, please return the decoder for repair (address on the cover page).

Manufacturer's note

According to DIN VDE 0869, the person who brings the circuit into operation by extension resp. mounting into a housing is the manufacturer of the product. If he sells the product to another person he is responsible for passing on all the relevant papers and to give his name and address.

Certification

This product conforms with the EC- directive 89/336/EWG on electromagnetic radiation and is therefore CE certified.

Conditions of warranty

This product is guaranteed for two years. The warranty includes the correction of faults which can be proved to be due to material failure or factory flaw. We guarantee the adherence to the technical specifications of the circuit when assembled and connected according to the manual.

Other claims are excluded. By law, we are not responsible for damages or secondary damages in connection with this product. We retain the right to repair, make improvements, supply spare parts or return the purchase price.

The following invalidate the warranty:

- using an unsuitable soldering iron, solder containing liquid acids or similar,
- if damage is caused by not following the instructions in this manual or the connection diagram(s),
- if the module has been altered and repair attempts have failed,
- if arbitrary changes in the circuit are made,
- additional components are added which are not described in the manual,
- if the copper tracks or soldering eyes are damaged,
- if damage occurs due to an overload of the module,
- if connected to a incorrect voltage or current,
- if damaged by other persons,
- if damaged by faulty operation or if damaged by careless use or abuse,
- if damaged by touching components before electrostatic discharging of the hands.

Fig. 1 / Fig. 2: Anschlußpläne - Connection Diagrams - Schémas de connexion - Aansluitplannen

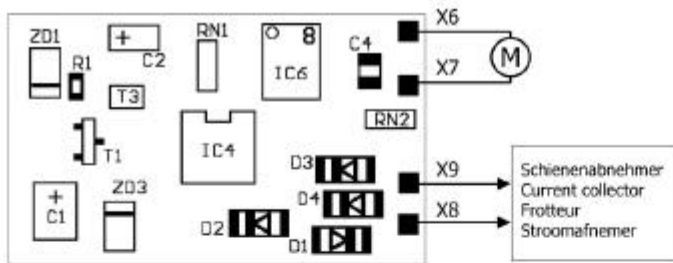

Fig. 1:
Rückseite des Lokdecoders - Rear of the locomotive decoder
Face arrière du décodeur - Achterzijde van de locdecoder

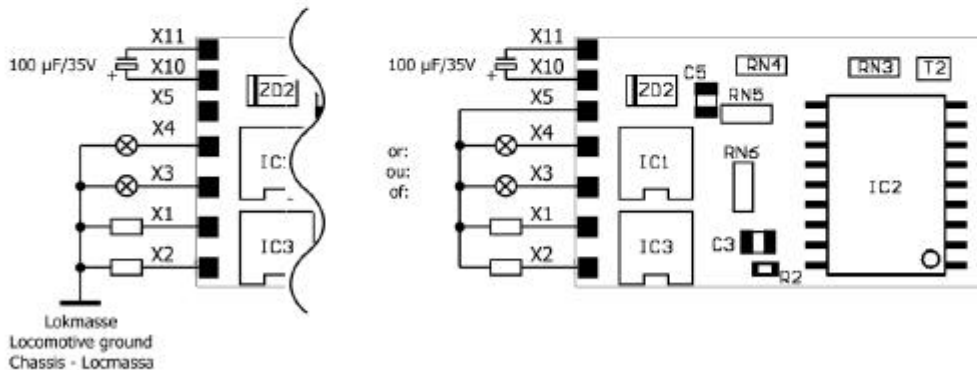
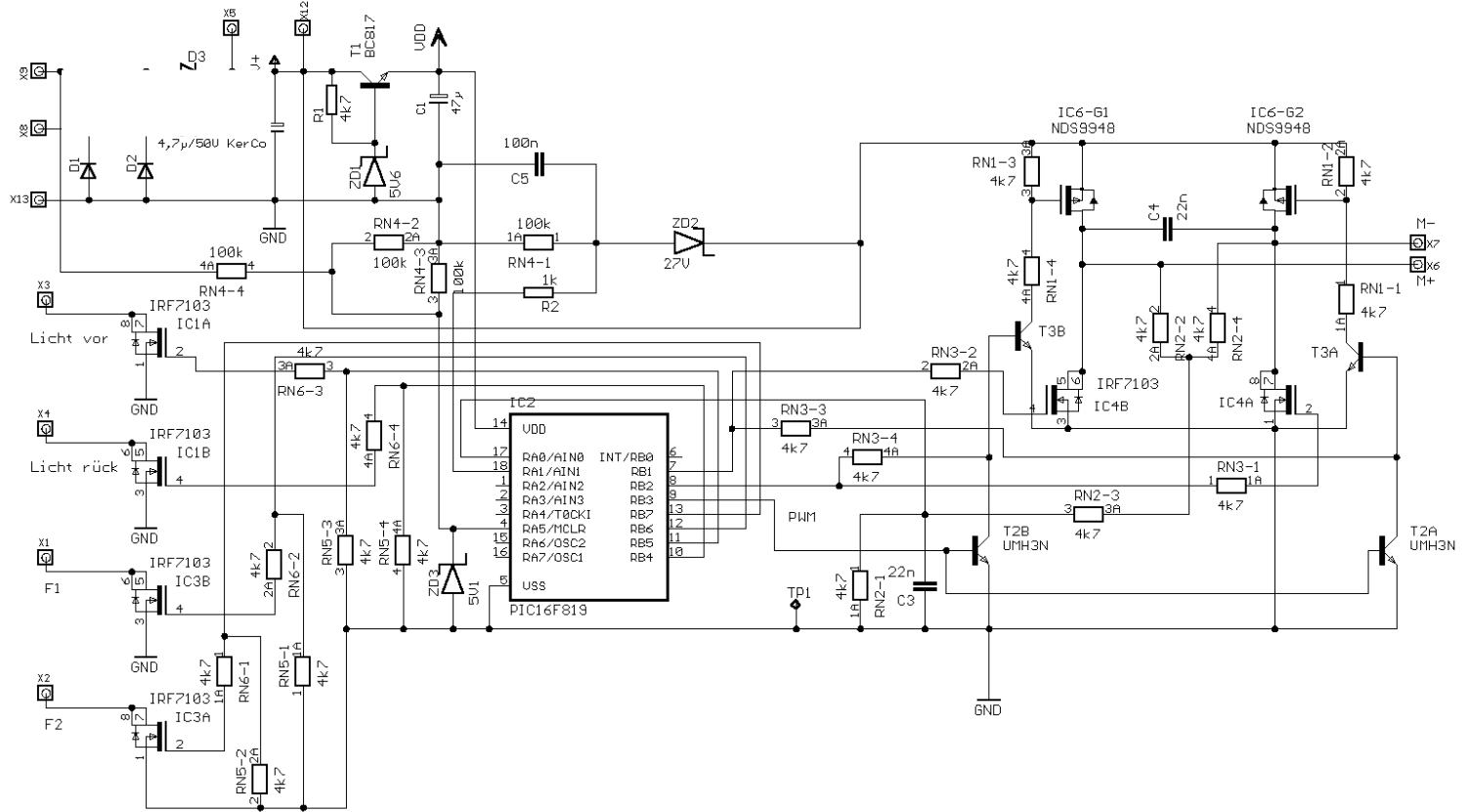

Fig. 2:
Vorderseite des Lokdecoders - Front of the locomotive decoder
Face avant du décodeur - Frontzijde van de locdecoder

X1 - X4	Beliebige Verbraucher Optional accessories Consommateurs quelconques Gewenste verbruikers
Belegung für werkseitige Einstellung: Connections for decoder factory settings: Occupation pour réglage d'origine: Plaatsing voor de fabriekmatige instelling:	
X1	F1
X2	F2
X3	Beleuchtung Rückwärtsfahrt Lighting backward direction Feux marche arrière Verlichting achteruitrijden
X4	Beleuchtung Vorwärtsfahrt Lighting forward direction Feux marche avant Verlichting vooruitrijden
X5	Rückleiter für alle Funktionen Return conductor for all functions Pole commun des fonctions Retourleiding voor alle functies
X6, X7	Motor - Moteur
X8, X9	Schienenabnehmer Current collector Frotteur Stroomafnemer
X10, X11	Elko, falls erforderlich Capacitor, if necessary Condensateur, si nécessaire Elco, indien noodzakelijk

Fig. 3: Schaltplan - Circuit Diagram - Schéma de principe - Schakelplan



Aktuelle Informationen und Tipps:

Information and tips:

Informations et conseils:

Actuele informatie en tips:

<http://www.tams-online.de>

Garantie und Service:

Warranty and service:

Garantie et service:

Garantie en service:

Tams Elektronik GmbH

Rupsteinstraße 10

D-30625 Hannover

fon: +49 (0)511 / 55 60 60

fax: +49 (0)511 / 55 61 61

e-mail: modellbahn@tams-online.de