

SD-5

Schaltdecoder

Switching decoder

Décodeur de commutation

Schakeldecoder

DCC

Art.-Nr. 21-01-069 / 22-01-069

Anleitung

Manual

WD-5

Weichendecoder

Points decoder

Décodeur d'aiguillage

Wisseldecoder

DCC

Art.-Nr. 21-01-067 / 22-01-067

Mode d'emploi

Handleiding



© 10/2004 Tams Elektronik GmbH

Alle Rechte, insbesondere das Recht der Vervielfältigung und Verbreitung sowie der Übersetzung vorbehalten. Vervielfältigungen und Reproduktionen in jeglicher Form bedürfen der schriftlichen Genehmigung durch die Tams Elektronik GmbH.

Technische Änderungen vorbehalten.



■ **Deutsch** **3**

■ **English** **21**

■ **Français** **37**

■ **Nederlands** **55**



© 10/2004 Tams Elektronik GmbH

All rights reserved. No part of this publication may be reproduced or transmitted in any form or by any means, electronic or mechanical, including photocopying, without prior permission in writing from Tams Elektronik GmbH.

Subject to technical modification.

© 10/2004 Tams Elektronik GmbH

Tout droits réservés, en particulier les droits de reproduction et de diffusion ainsi que le traduction. Toute duplication ou reproduction sous quelque forme que ce soit nécessite l'accord écrit de la société Tams Elektronik GmbH.

Sous réserve de modifications techniques.

© 10/2004 Tams Elektronik GmbH

Alle rechten voorbehouden. Niets uit deze publicatie mag worden vermenigvuldigd opgeslagen of openbaar gemaakt, zonder voorafgaande schriftelijke toestemming van Tams Elektronik GmbH.

Technische wijzigingen voorbehouden.

Table of contents

How to use this manual	22
Intended use	22
Safety instructions	22
EMC declaration	24
Operation overview	25
Technical specifications	25
Checking the package contents	26
Required tools and consumables	26
Safe and correct soldering	26
Assembling the kit	28
Performing a visual check	32
Connecting the decoder	33
Programming the address	33
FAQ	34
Manufacturer's note	35
Certification	35
Conditional warranty	35
Parts list - switching decoder SD-5	I.1
Printed Circuit Board (PCB) layout - switching decoder SD-5 (Fig. 1)	I.2
Parts list - points decoder WD-5	II.1
Printed Circuit Board (PCB) layout - points decoder WD-5 (Fig. 2)	II.2
Circuit Diagram - switching decoder SD-5 (Fig. 3)	III
Circuit Diagram - points decoder WD-5 (Fig. 4)	IV
Connections - switching decoder SD-5 (Fig. 5)	V
Connections - points decoder SD-5 (Fig. 6)	VI
(Pages I to VI in the centre of this handbook are removable.)	

How to use this manual

If you have no specialist technical training, this manual gives step-by-step instructions for safe and correct assembly of the kit and fitting of the ready-built module, and operation. Before you start, we advise you to read the whole manual, particularly the chapter on safety instructions and the FAQ chapter. You will then know where to take care and how to prevent mistakes which take a lot of effort to correct.

Keep this manual safely so that you can solve problems in the future. If you pass the kit on to another person, please pass on the manual with it.

Intended use

Caution:

Integrated circuits are very sensitive to static electricity. Do not touch components without first discharging yourself. Touching a radiator or other grounded metal part will discharge you.

The kit or the ready-built module can be assembled or fitted using this manual. The ready-built module is designed for use in model railways. It evaluates the DCC format data sent by the digital central unit to its' address and switches up to four connected loads (SD-5) or up to four points or other solenoid accessories (WD-5).

The kit and the ready-built module are not suitable for children under the age of 14. Reading, understanding and following the instructions in this manual are mandatory for the user. Any other use is inappropriate and invalidates any guarantees.

Safety instructions

Mechanical hazards

Cut wires can have sharp ends and can cause serious injuries. Watch out for sharp edges when you pick up the PCB.

Visibly damaged parts can cause unpredictable danger. Do not use damaged parts: recycle and replace them with new ones.

Electrical hazards

- Touching powered, live components,
- touching conducting components which are live due to malfunction,
- short circuits,
- connecting the circuit to another voltage than designed
- impermissibly high humidity,
- condensation building up

can cause serious injury due to electrical shock. Take the following precautions to prevent this danger:

- Never perform wiring on a powered module.
- Assembling and mounting the kit should only be done in closed, clean, dry rooms. Beware of humidity.
- Only use low power for this module as described in this manual and only use certified transformers.
- Connect transformers and soldering stations only in approved mains sockets installed by an authorised electrician.
- Observe cable diameter requirements.
- After condensation build up, allow up to 2 hours for dispersion.
- Use only original spare parts if you have to repair the kit or the ready-built module.

Fire risk

Touching flammable material with a hot soldering iron can cause life-threatening fire, burns and toxic smoke. Connect your soldering iron or soldering station only when actually needed. Always keep the soldering iron away from inflammable materials. Use a suitable soldering iron stand. Never leave a hot soldering iron or station unattended.

Thermal danger

A hot soldering iron or liquid solder accidentally touching your skin can cause skin burns. As a precaution:

- use a heat-resistant mat during soldering,
- always put the hot soldering iron in the soldering iron stand,

- point the soldering iron tip carefully when soldering, and
- remove liquid solder with a thick wet rag or wet sponge from the soldering tip.

Dangerous environments

A working area that is too small or cramped is unsuitable and can cause accidents, fires and injury. Prevent this by working in a clean, dry room with enough freedom of movement.

Other dangers

Children can cause any of the accidents mentioned above because they are inattentive and not responsible enough. Children under the age of 14 should not be allowed to work with this kit or the ready-built module.

Little children can swallow small components with sharp edges. Life threatening! Do not allow components to reach small children.

In schools, training centres, clubs and workshops, assembly must be supervised by qualified personnel. In industrial institutions, health and safety regulations applying to electronic work must be adhered to.

EMC declaration

This product is developed in accordance with the European standards EN 55014 and EN 50082-1, tested corresponding to the EC - directive 89/336/EEG (EMVG of 09/11/1992, electromagnetic tolerance) and meets legal requirements.

To guarantee the electromagnetic tolerance you must take the following precautions:

- Connect the transformer only to an approved mains socket installed by an authorised electrician.
- Make no changes to the original parts and accurately follow the instructions, circuit diagram and connections diagrams included with this manual.
- Use only original spare parts if you have to repair the kit or the ready-built module.

Operation overview

The decoder receives the digital data in DCC format sent by the central unit to its' address(es). It evaluates the signals and switches the relevant accessory (SD-5) or points / solenoid article (WD-5).

It is possible to connect one accessory to be switched on and off or two accessories to be switched over to each of the four outputs of the switching decoder.

The setting of the address(es) is done through the programming push-button. It is possible to set either four successive points decoder addresses (e.g. 1 to 4, 5 to 8, 9 to 12 etc.) or one locomotive address. When a locomotive address is set, the accessories or the points are switched via the function keys F1 to F4.

It is possible to supply the decoder via the central unit or a booster. Alternatively it can be supplied by its own transformer to reduce possible overloading elsewhere.

Technical specifications

Supply voltage	Digital voltage of the central unit or 14 – 20 V alternating voltage
Current consumption (without connected loads)	ca. 20 mA
Max. current loading	1.500 mA
Protected to	IP 00
Ambient temperature in use	0 - + 60° C
Ambient temperature in storage	-10 - + 80° C
Comparative humidity allowed	max. 85 %
Dimensions	ca. 73 x 80 mm
Weight	ca. 47 g

Checking the package contents

Check the contents of the package for completeness immediately after unpacking:

- one kit, containing the components listed in the parts list (see page I / II) and one PCB or
- one ready-built module,
- one manual.

Required tools and consumables

Make sure you have the following tools, equipment and materials ready for use:

- an electronic soldering iron (max. 30 Watt) with a fine tip,
- a soldering iron stand,
- a tip-cleaning sponge,
- a heat-resistant mat,
- a small side cutter and wire stripper,
- a pair of tweezers and long nose pliers (not necessary for the ready-built module),
- tin solder (0,5 mm diameter),
- wire (diameter: $\geq 0,22 \text{ mm}^2$ for all connections).

Safe and correct soldering

Caution:

Incorrect soldering can cause dangers through fires and heat. Avoid these dangers by reading and following the directions given in the chapter **Safety instructions**. If you have had training in soldering you can skip this chapter.

- Use a small soldering iron with max. 30 Watt. Keep the soldering tip clean so the heat of the soldering iron is applied to the solder point effectively.
- Only use tin solder SN 60 Pb (i.e. 60 % tin, 40 % lead) with rosin-based flux.
- When soldering electronic circuits never use soldering-water or soldering grease. They contain acids that can corrode components and copper tracks.
- Solder fast: long soldering can destroy components and can damage copper tracks or soldering eyes.
- Observe correct polarity orientation of semi-conductors, LEDs electrolytic capacitors and integrated circuits before soldering and ensure that the solder time does not exceed 5 seconds, otherwise components can be damaged.
- Apply the soldering tip to the soldering spot in such a way that the part and the soldering eye are heated at the same time. Simultaneously add solder (not too much). As soon as the solder becomes liquid take it away. Hold the soldering tip at the spot for a few seconds so that the tin solder finds its way, then remove the soldering iron.
- Do not move the component for about 5 seconds after soldering. A glossy and perfect soldering spot should remain..
- To make a good soldering joint you must use a clean and unoxidised soldering tip. Clean the soldering tip with a damp piece of cloth, a damp sponge or a piece of silicon cloth.
- Cut the wires after soldering directly above the PCB solder side with a side cutter.
- After placing the parts, please double check for correct polarity. Check the PCB tracks for solder bridges and short circuits created by accident. This would cause faulty operation or, in the worst case, damage. You can remove excess solder by putting a clean soldering tip on the spot. The solder will become liquid again and flow from the soldering spot to the soldering tip.

Assembling the kit

You can skip this part if you have purchased a ready-built module

Preparation

Put the sorted components in front of you on your workbench. The separate electronic components have the following special features you should take into account to prevent mistakes in assembling:

Resistors

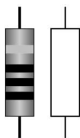

Resistors reduce current. Their mounting orientation is of no importance. The value of resistors for smaller power ratings (under 5 W) is indicated through colour rings. Every colour stands for another figure. The colour ring in brackets indicates the tolerance of the resistor which here is of no importance.

Value	Colour rings
0,27 Ω	red - violet - silver (gold)
1 k Ω	brown - black - red (gold)
1,5 k Ω	brown - green - red (gold)
2,2 k Ω	red - red - red (gold)
5,6 k Ω	green - blue - red (gold)
10 k Ω	brown - black - orange (gold)

Capacitors



Among other things capacitors are used for filtering interference voltages or as frequency determining parts. Ceramic capacitors are not polarized, for that reason their mounting orientation is of no importance. Normally they are marked with a three-digit number which indicates the value coded.

Value	Number
100 nF	104

Electrolytic capacitors

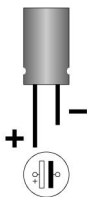

Electrolytic capacitors are often used to store energy. In contrast to ceramic capacitors they are polarized. One of the two leads is marked with a minus sign which indicates the mounting orientation. The value is given on the casing.

Electrolytic capacitors are available with different voltage sustaining capabilities. Using an electrolytic capacitor with a voltage sustaining capability higher than required is always possible.

Diodes

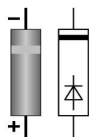

Diodes allow the current to pass through in one direction only (forward direction), simultaneously the voltage is reduced by 0,3 to 0,8 V. Exceeding of the limit voltage always will destroy the diode, and allow current to flow in the reverse direction.

The diode type is printed on the body.

Diodes must be mounted in a given direction. The Negative end is marked with a ring. This is shown in the PCB layout.

Zener diodes

Zener diodes are used for limiting voltages. In contrast to „normal“ diodes they are not destroyed when the limit voltage is exceeded.

Transistors

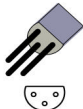

Transistors are current amplifiers which convert low signals into stronger ones. They have three contacts. As they are polarized, they have to be mounted in a certain direction.

BC-Types have a housing in form of a half cylinder (SOT-housing). The cross section is shown in the PCB Layout which determines the mounting orientation.



The BD types have a flat housing (TO-housing) with the type designation printed on the front side. The metallic rear is unlabelled, on the PCB layout the rear is marked by a thick line.

Integrated circuits (ICs)

Depending on the type, ICs fulfil various tasks. They are polarized and therefore have to be mounted in a certain direction. The most common housing form is the so-called "DIL"-housing, from which 4, 6, 8, 14, 16, 18 or more "legs" (pins) are arranged along the long sides. The mounting orientation is shown by a semicircular or circular marking at the end of the housing, which is also shown on the PCB layout.

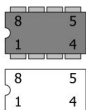

ICs are sensitive to damage during soldering (heat, electrostatic charging). For that reason in the place of the ICs IC sockets are soldered in, in which the ICs are inserted later. The mounting orientation of the sockets is preset as well. The markings on the PCB, the socket and the IC must lie on top of each other after mounting.

Micro-Controller

Micro-controller are ICs, which are individually programmed for the particular application. When leaving the manufacturer's works their memory is empty. The programmed controller normally are only available from the manufacturer of the circuit belonging to it.

Opto couplers

Opto couplers are ICs, which work similar to laser beam switches. They combine in one housing a light emitting diode and a photo transistor. Their task is the transmission of information without galvanic connection. Normally they are in a DIL-housing with 4, 6 or 8 pins.

Relays

Relays are electronic switches, depending on their position the one or other (internal) connection is closed. Their mode of operation can be compared to that of a push-button switch, i.e. the connection is only

closed as long as the voltage is applied. Bistable relays keep their status after switching – comparable to a switch.

Relays which combine two switches in one housing are common as well (shortly 2xUM). The switching between the two connections can be heard clearly because of the resulting clicking sound.

The mounting orientation of the relays which are put in a rectangular box shaped housing is given by the layout of the pins.

Terminal strips

Terminal strips are solder-in screw-type terminals. They provide a solder-free and safe connection of the cables to the circuit, which can still be separated any time. When several terminal strips have to be mounted side by side, they have to be put together before mounting.

Assembling the kit

Start the assembly with the resistors and the diodes. First solder the components on the solder side of the PCB and then cut the excess wires with the side cutter, as short as possible. Insert the wire bridges Br1 and Br2. Use the off-cut wires of the resistors.

Then insert and solder in the IC-sockets. The sockets must be mounted according to the marking on the PCB. Continue the assembly with the capacitors, the electrolytic capacitors and the transistors.



Caution:

Diodes, electrolytic capacitors and transistors must be placed in the right direction! If you solder them the wrong way the affected parts can be damaged when you connect the power. In the worst case the whole circuit can be damaged. In any case, a wrongly connected part will not function.

Then solder in the solder pin and the terminal strips. Before mounting, assemble the terminal strips. Finally, insert the ICs into the soldered IC-sockets.

Finally, insert the ICs into the soldered IC-sockets.

 **Caution:**

Do not touch the ICs without first discharging yourself by touching a radiator or other grounded metal parts. Do not bend the "legs" of the ICs when inserting them into the sockets. Check that the markings on the PCB, the socket and the IC show to the same direction.

Connect the programming push-button with the 2-pole contact strip. Afterwards put the contact strip on the solderpin JP1.

Performing a visual check

Due to material defects and/or improper assembly there may be risks of injury. Transport damage to ready-built modules is also possible. So you must perform a visual check after the assembly or after unpacking the module.

 **Caution:**

Do not power up the module yet.

Check all nuts, pins and connections as well as the mechanical connections for correct assembly.

The following points are inapplicable if you have purchased a ready-built module.

Remove all loose parts, wire ends or drops of solder from the PCB. Remove all sharp wire ends.

Check that solder contacts which are close to each other are not unintentionally connected to each other. Risk of short circuit!

Check that all components are polarised correctly.

When you have remedied all faults, go on to the next part.

Connecting the decoder

Follow the connections diagrams fig. 5 (SD-5) and 6 (WD-5).



Caution:

If a component gets too hot, disconnect the decoder and the power supply from the mains **immediately**. Possible short circuit! Check the assembly!



Caution:

Switch off the central unit before connecting the decoder.

There are terminal strips soldered to the in- and outputs. Insert the connecting cables into the relevant terminals and fasten the screws. The connecting diagram shows the correct assembly.

Start by connecting the points with the relevant outputs of the points decoder or the accessories with the relevant outputs of the switching decoder.

Next connect the decoder with the central unit and the power supply. If you want to supply the decoder via the central unit, you must connect the terminal strips X2 and X3 according to fig. 5 resp. 6 to each other and the central unit with X2. If you want to supply the decoder via a transformer of its own connect the central unit to X2 and the transformer to X3 (see fig. 5a resp. 6a).

Programming the address

In the factory setting the decoder reacts to the points decoder addresses 1 to 4. To change the address, proceed as follows:

Operate the programming push-button. The accessory connected to R1 and G1 now switches on and off continuously or the points connected to R1 and G1 switches over continuously. This indicates that the decoder is in the programming mode. Now you may set the points or locomotive decoder address.

Setting a points decoder address: Enter any address from the quadruple address block with which you want to switch the connected accessories or points (e.g. address „10“ from the quadruple address block 9 – 12). Switch this accessory or this points (the current setting of the accessory or the points is of no importance). The decoder confirms the taking over of the address by a quicker switching on and off of the accessory or a quicker switching over of the points and returns automatically to standard operation.

Setting a locomotive decoder address: Enter a locomotive decoder address at the central unit after entering the programming mode and switch one of the functions F1 to F4. The decoder confirms the taking over of the address by a quicker switching on and off of the accessory or a quicker switching over of the points and returns automatically to standard operation. In operation you may switch the accessories or the points via the function keys F1 to F4.

 **Caution:**

If the programming mode is not settled with a switching command the decoder returns to standard operation after some time and the old address is stored.

FAQ

- Parts are getting too hot and/or start to smoke.



Disconnect the system from the mains immediately!

Possible cause: one or more components are soldered incorrectly.

→ Perform a visual check.

- The decoder does not work.

Possible cause: The connection of the decoder to the central unit and / or the power supply is interrupted. → Check the connections.

Possible cause: The connection of the decoder to the accessory or the points is interrupted. → Check the connections.

Possible cause: The central unit is not operating.

→ Check if the central unit is ready for operation.

Possible cause: The connected accessory or the connected points is defective. → Check the accessory or the points.

If you cannot find the problem, please return the module for repair (address on the cover page).

Manufacturer's note

According to DIN VDE 0869, the person who builds this kit or brings the circuit into operation is the manufacturer of the product. If he sells the product to another person he is responsible for passing on all the relevant papers. Domestic appliances assembled from a kit are deemed industrial products and must comply with health and safety regulations

Certification

This product conforms with the EC- directive 89/336/EWG on electromagnetic radiation and is therefore CE certified.

Conditions of warranty

This product is guaranteed for two years. The warranty includes the correction of faults which can be proved to be due to material failure or factory flaw. As we have no control over the correct and proper assembly and mounting we can only guarantee the quality of the components and the completeness of kits. We guarantee the function of the parts according to the parameters in not mounted state as well as the adherence to the technical specifications of the circuit when assembled and connected according to the manual.

Other claims are excluded. By law, we are not responsible for damages or secondary damages in connection with this product. We retain the right to repair, make improvements, supply spare parts or return the purchase price.

The following invalidate the warranty:

- using an unsuitable soldering iron, solder containing liquid acids or similar,
- if the kit is assembled and soldered poorly, or if damage is caused by not following the instructions in this manual or the connection diagram(s)
- if the ready-built module has been altered and repair attempts have failed,
- if arbitrary changes in the circuit are made,
- if components are removed or swapped, or wiring is added or removed in any other way as layed down in the original design.
- if parts other then the original ones delivered with this kit are used,
- if the copper tracks or soldering eyes are damaged,
- when components are mounted incorrectly, or if the components or the circuit are poled incorrectly, also subsequent damage resulting from these faults,
- if damage occurs due to an overload of the module,
- if connected to a incorrect voltage or current,
- if damaged by other persons,
- if damaged by faulty operation or if damaged by careless use or abuse,
- if damaged by touching components before electrostatic discharging of the hands.

WD-5: Stückliste - Parts list Nomenclature - Stuklijst

Widerstände Resistors Résistances Weerstanden	R4	0,27 Ω
	R6	1 k Ω
	R8-R15	1,5 k Ω
	R1, R3, R5	2,2 k Ω
	R7	5,6 k Ω
	R2	10 k Ω
Kondensatoren - Condensers Condensateurs - Condensatoren	C1, C6	100 nF
	C2, C3	220 μ F/25 V
Dioden – Diodes	D1-D12	1N4004 *
Zener-Dioden - Zener diodes Diodes Zener -Zenerdiodes	D13	ZD 5,1 V *
	D14	ZD 47 V *
Transistoren - Transistors	Q1	BC557B *
	T1-T8	BD680 *
IC 's - ICs - CI 's - ICs	IC1	PIC12C629P
	IC2	74HC138N
	OK1	PC827
IC-Sockel - IC-socket Soquet IC - IC-voetje	IC1, OK1	8-pol.
	IC2	16-pol.
Anreihklemmen - Terminal strips Borniers - Printkroonsteen	X1	12-pol.
	X2, X3	2-pol.
Stiftleiste - Solder pin Barette – Pinstrip	JP1	2-pol.
Buchsenleiste / Contact strip / Fiche / aansluitbus	JP1	2-pol.
Programmiertaster / programming push button touche de programmation / programmeertoets		1 x

* oder ähnlich - or similar - ou équivalent - of gelijkwaardig

WD-5: Bestückungsplan - PCB layout Plan d'implantation - Printplan

■ Fig. 2

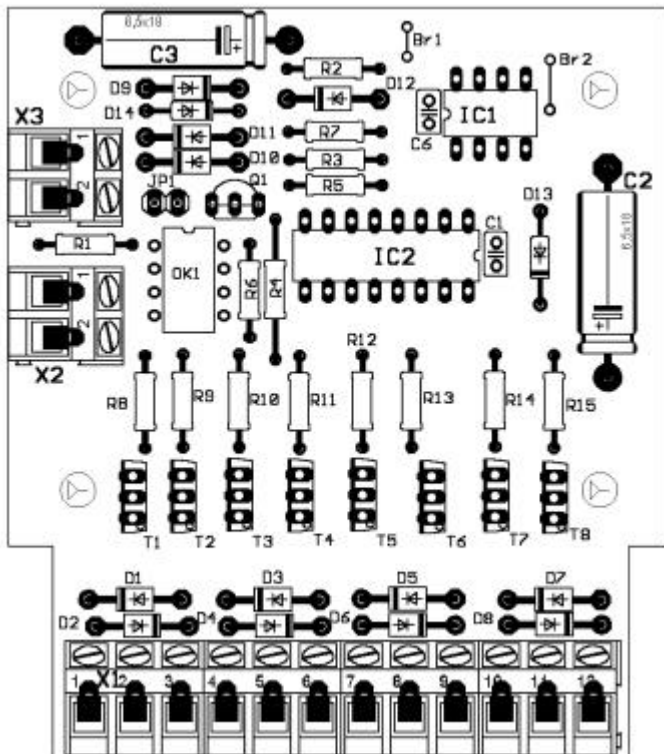

WD-5: Anschlußplan – Connections – Plan de raccordement – Aansluit plan

■ Fig. 6

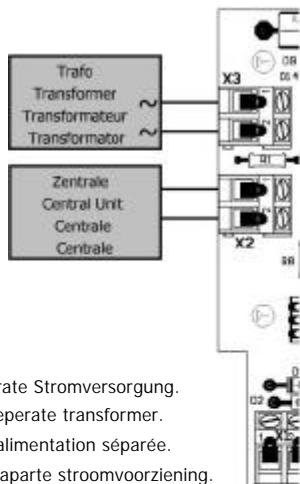
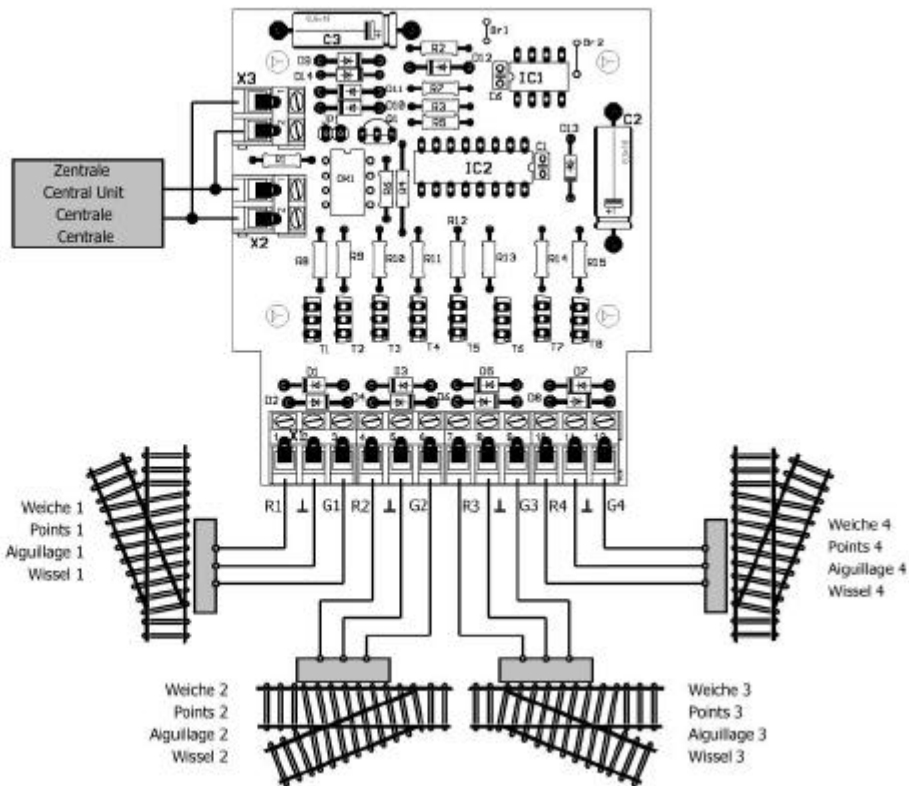

Fig. 6a:

Anschluß an separate Stromversorgung.
 Connection to a separate transformer.
 Connexion à une alimentation séparée.
 Aansluiting op de aparte stroomvoorziening.



Aktuelle Informationen und Tipps:

Information and tips:

Informations et conseils:

Actuele informatie en tips:

<http://www.tams-online.de>

Garantie und Service:

Warranty and service:

Garantie et service:

Garantie en service:

Tams Elektronik GmbH

Rupsteinstraße 10

D-30625 Hannover

fon: +49 (0)511 / 55 60 60

fax: +49 (0)511 / 55 61 61

e-mail: info@tams-online.de